

Instructions

Type AQ Valve Position Monitors are designed to provide high accuracy feedback of valve position to plant control systems. These instructions outline the requirements for ensuring a long and trouble free service life from the monitors.

Installation - Mounting

Attach mounting plate (1) to the actuator using fasteners (2) and lockwashers (2a) provided with mounting kit (if supplied by Imtex).

Loosen indicator cover set screw (3) and rotate indicator cover (4) to desired viewing angle. Retighten set screw (3).

Rotate coupling spacer (5) and indicator drum (6) to desired position (OPEN or CLOSED appearing through indicator window).

Fit torque coupler (7) or NAMUR drive block (7a) using screw (8) supplied in kit.

Fit monitor assembly to actuator ensuring that the torque coupler/NAMUR drive block (7/7a) engages the pinion of the actuator (9). Secure the assembly using the bolts (10) and lockwashers (11) provided with the mounting kit. Fine tune the indicator cover (4) by loosening set screw (3). Retighten set screw when completed.

Operate the actuator to ensure proper alignment between monitor and actuator. Eccentricity of the shaft must not exceed 0.25mm. If it should be necessary, re-align monitor by loosening mount bolts (10). Retighten bolts when satisfied with alignment.

Installation - Wiring & Switch Setting

Once the monitor is fitted to the actuator, remove cover (12). NOTE: If fitted, the cover lock screw (13) must be loosened prior to cover removal.

Bring field wiring into the enclosure via the conduit entries (14) fitted with a suitable cable gland. Use blanking plugs to block off any un-used cable entries. NOTE: Suitable IP6x rated cable glands, blanking plugs and thread adaptors must be used to maintain monitor IP rating.

Connect field wiring to the terminals (15) within the enclosure according to the wiring diagram and terminal labelling.

For monitors fitted with standard cam/spline activated switches/sensors, drive the actuator to the first required indication position and set the bottom switch by lifting and rotating the bottom cam (16). Secure the cam by allowing it to fully re-engage with the spline (17). Repeat the process for each switch in-turn by lifting/pushing down the appropriate cam, rotating and re-engaging as desired position is reached.

For monitors with barrel or slotted sensors, or with a transmitter, consult page 2 of these instructions for 'Further Setting Instructions'.

Once completed, verify that indication is required by fully stroking the actuator. Then refit cover (12).

SPECIAL CONDITIONS FOR CERTIFIED ENCLOSURES - ATEX

Installation should be carried out by suitably trained personnel to an applicable Code of Practice (eg IEC/EN60079-14).

Each connected circuit MUST be wired to a compatible, certified Intrinsically Safe Barrier



WARNING - Electrostatic Hazard: Clean Only with a Damp Cloth.

WARNING - Do not install on an external source of heating or cooling e.g. by hot/cold air blowing temperature units

Maintenance

The Type AQ requires no servicing during normal working life, if installed correctly. However, it is advisable to check mounting screws/bolts, o-rings and terminal wiring for signs of loosening or corrosion as part of the routine plant maintenance to ensure continued operation.

Ensure safety warnings are observed during maintenance. Inspection & maintenance to ATEX enclosures to be carried out by suitably trained personnel with applicable code of practice (eg IEC/EN60079-17).

Repairs to Type AQ ATEX enclosures are not normally permitted. Please consult factory.

Reference Diagram

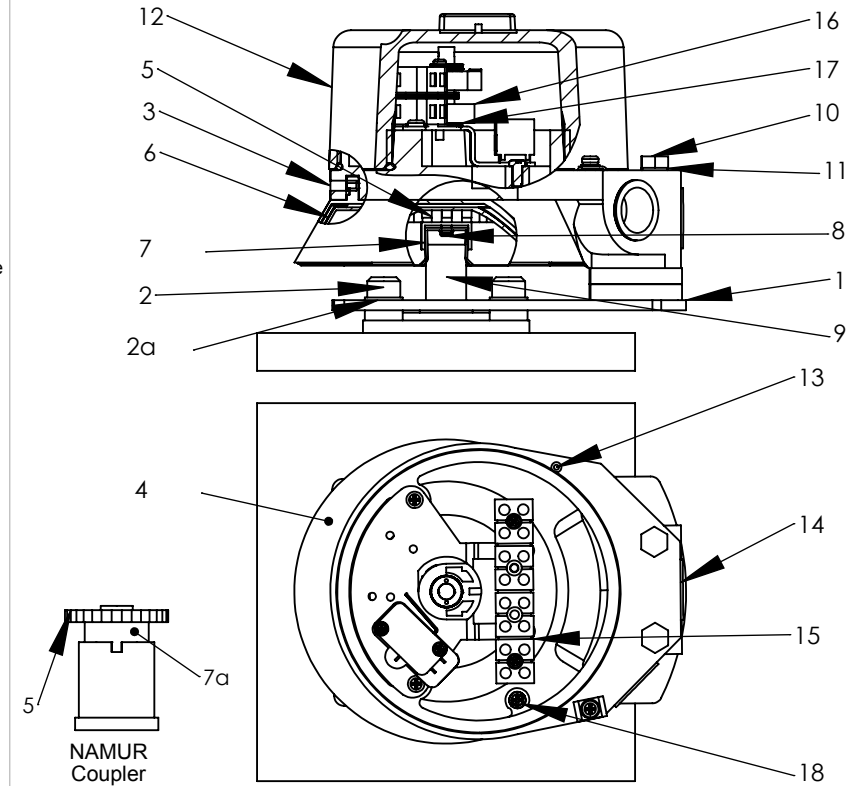

REV	DRAWN	DATE	CHK'D	ECO
	PT	14.8.14		14-2270
A	PT	14.2.17		17-2618
B	PT	1.2.18		18-2692

Intex Controls Limited
Deeside - United Kingdom

Website: www.intex-controls.com

TITLE:

Installation, Operating & Maintenance

AQ - ATEX

DWG NO.

A190317

REV
B
STATUS
R

SHEET 1 OF 5

Further Setting Instructions

Barrel/Slot Sensor Setting

Drive the actuator to the first required indication position and set the first switch by pushing round the lower metal shim on the shaft (16) to cover the sensor.

Repeat the process for each sensor in-turn by driving the actuator to the indication position and adjusting the appropriate shim to cover the corresponding sensor.

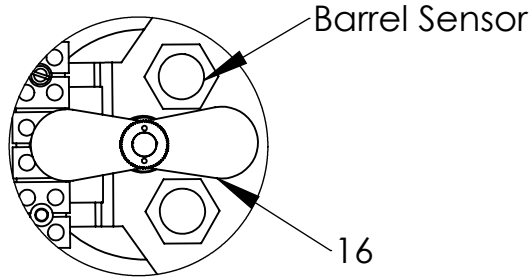

Transmitter Setting

NOTE: The Type AQ Transmitter is factory set to provide position information over a 90 Degree span.

To reset the zero and span:

Drive the actuator to the position intended to indicate the 'low' signal. Set the zero point for the transmitter either locally (when available) or using suitable configuration software. Drive the actuator to the position intended to indicate the 'high' signal. Set the span point either locally (where applicable) or using suitable configuration software.

To set the switches/sensors supplied in the enclosure with the transmitter, if supplied, refer to page one of these instructions.

Referenced Standards

The following standards have been referred to in these instructions and are applicable to the use of this product when used in an environment where an explosive atmosphere may be present:

- IEC 60079-0:2017 7th Ed
- IEC60079-11:2011 6th Ed
- IEC 60079-31:2013 2nd Ed
- EN60079-0:2012
- EN60079-11:2012
- EN60079-31:2014

Cable Entries

The number and type of cable entry on the Monitor can be determined by reference to the 6th digit of the monitor part number. For example, in part number -

AQ16S5SR

the sixth digit is a '5' which corresponds to the monitor having 2 off M20 x 1.5 cable entry. Refer to table below for details.

CABLE ENTRY GUIDE	
DIGIT	ENTRIES SUPPLIED
5	(2) M20 x 1.5
6	(3) M20 x 1.5
8	(1) 3/4" NPT (central entry) (1) 1/2" NPT (offset entry)
9	(1) 3/4" NPT (central entry) (2) 1/2" NPT (offset entry)
B	(2) 1/2" NPT
C	(3) 1/2" NPT

NPT Threads conform to ANSI/ASME B1.20.1 and shall be made up wrench tight

Metric Thread tolerance to ISO 965-1 and ISO 965-3

Certification

Classification:

Exia IIC T4/T5/T6 Gb (dependent on ambient temperature range)

Product Markings

The label on the monitor should be as below:

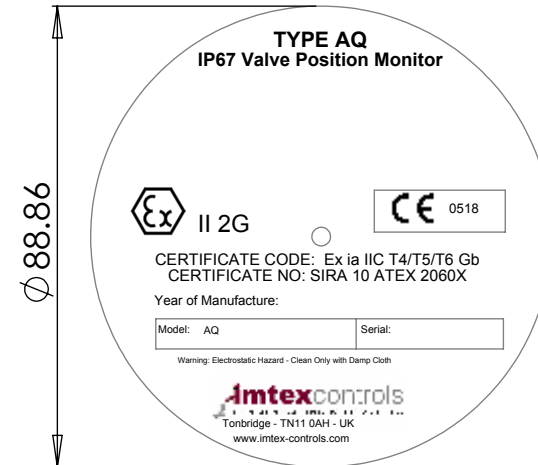

REV	DRAWN	DATE	CHK'D	ECO
	PT	14.8.14		14-2270
A	PT	14.2.17		17-2618
B	PT	1.2.18		18-2692

TITLE:

Installation, Operating & Maintenance

AQ - ATEX

This private & confidential drawing is the property of Imtex Controls Limited, Tonbridge, UK and cannot be copied or reproduced without the express written permission of the Company.

Imtex Controls Limited
Deeside - United Kingdom

Website: www.imtex-controls.com

DWG NO.

A190317

REV
B
STATUS
R

ELECTRICAL CHARACTERISTICS ('X' Indicates the applicable Rating(s))

17 & 56 - Mechanical w/ Gold Contacts

Electrical Ratings: 1.0A @ 125VAC
0.5A @ 30 VDC
Temp Range: -40 to +60 °C
Operating Life: 100,000 Cycles

Recommended for use in 24VDC computer input circuits

25, 58 & 40, 59 (A140077) - SPST & SPDT Reed Switch

Electrical Ratings: 0.5A (Switching Current)
1.0A Max (Steady State Current)
120V Max (Voltage)
10W/VA Max (Power)
Temp. Range: -50 to +60 °C (T6) or +85 °C (T4)
Operating Life: 5,000,000 Cycles

25, 58 & 40, 59 (A140077-SU) SPST & SPDT (Hermetically Sealed Reed w/ Choke)

Electrical Ratings: 0.15A @ 125VAC / 30VDC
Inductance: 680 µH
Resistance: 10Ω
Temp. Range: -40 to +60 °C
Operating Life: 5,000,000 Cycles

42 & 52 - NAMUR Proximity Sensor

Current Ratings: Target Present - Current < 1.0mA
Target Absent - Current > 3.0mA
Voltage Range: 5 to 25VDC (nominal 8VDC)
Temp. Range: -25 to +60 °C (T6) or +72 °C (T4)
Operating Life: Unlimited Cycles

Use with intrinsically safe repeater barrier. Namur sensors fully conform to EN60947-5-6 (VDE0660 Part 212) standard.

43 & 53 - NAMUR Proximity Sensor

Current Ratings: Target Present - Current < 1.0mA
Target Absent - Current > 3.0mA
Voltage Range: 5 to 25VDC (nominal 8VDC)
Temp. Range: -50 to +60 °C (T6) or +85 °C (T4)
Operating Life: Unlimited Cycles

Use with intrinsically safe repeater barrier. Namur sensors fully conform to EN60947-5-6 (VDE0660 Part 212) standard.

70 - Analogue Transmitter - Non-Contact Style

Supply Voltage: 12 to 24VDC
Load Impedance: R< (U - 9) / 0.02
Linearity: < 1% of FS
Repeatability: < 0.36°
Op Temp Range: -40 to +85 Deg C

Other Details (see Individual Specification Sheet)

70 - Analogue/Digital Transmitter - Programmable

Supply Voltage: 8 to 30VDC
Internal Consumption: 25mW to 0.8W
Voltage Drop: 8VDC
Warm Up Time: 5 min
Comms Link: Loop
Signal / Noise Ratio: min 60 dB
Min Response Time: 0.33 s
Calibration Temp: +20 to +28 Deg C
Op Temp Range: -40 to +60 Deg C

SPECIAL NOTE:

Installation of Reed Switches (without Choke): Where reed switches are installed at the end of long cable runs, it is the responsibility of the installer to ensure suitable precautions are taken to ensure cable capacitance does not induce premature switch failure. Consult Imtex for further information

Installation of Reed Switches (withChoke): Where a reed switch with choke is used, the installer must carry out an ignition capability assessment of the full circuit (in accordance with EN60079-11:2012,Annex A).

REV	DRAWN	DATE	CHK'D	ECO
	PT	14.8.14		14-2270
A		14.2.17		17-2618
B		1.2.18		18-2692

TITLE:
**Installation, Operating & Maintenance
AQ - ATEX**

This private & confidential drawing is the property of Imtex Controls Limited, Tonbridge, UK and cannot be copied or reproduced without the express written permission of the Company.

Imtex Controls Limited
Deeside - United Kingdom

Website: www.imtex-controls.com

DWG NO. **A190317**

REV
B
STATUS
R

WIRING DIAGRAMS ('X' Indicates the applicable Diagram)

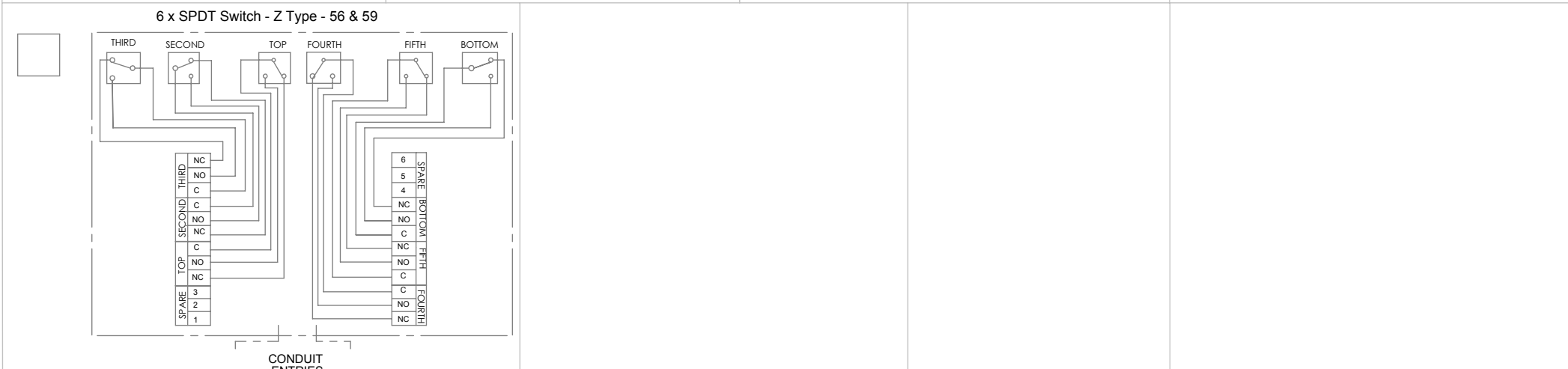
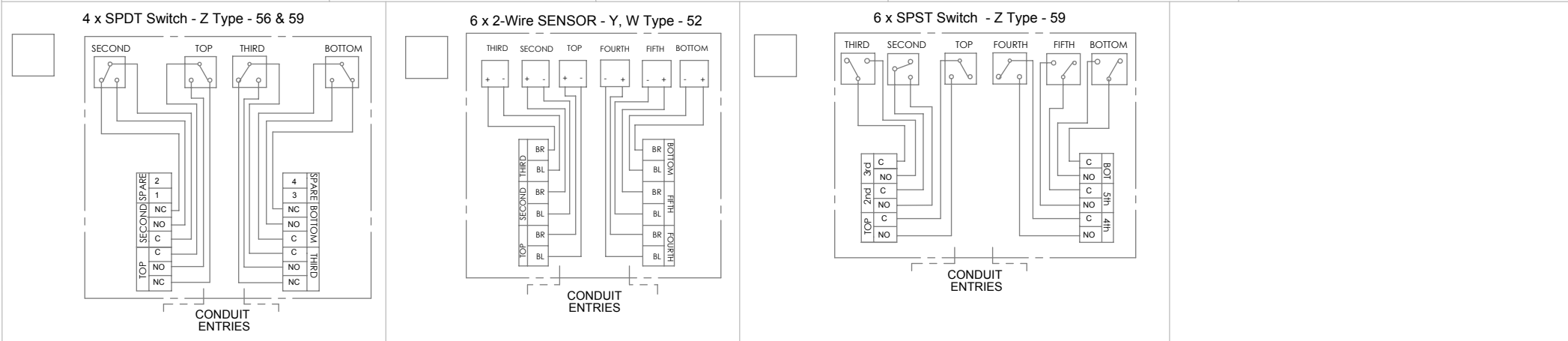
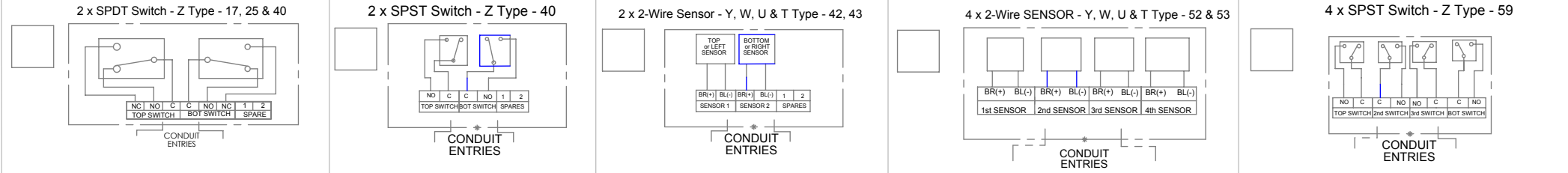

REV	DRAWN	DATE	CHK'D	ECO
	PT	14.8.14		14-2270
A	PT	14.2.17		17-2618
B	PT	1.2.18		18-2692

TITLE:
**Installation, Operating & Maintenance
AQ - ATEX**

This private & confidential drawing is the property of Imtex Controls Limited, Tonbridge, UK and cannot be copied or reproduced without the express written permission of the Company.

Imtex Controls Limited
Deeside - United Kingdom

Website: www.imtex-controls.com

DWG NO. **A190317**

	REV B
	STATUS R
	A4

WIRING DIAGRAMS ('X' indicates the applicable diagram)

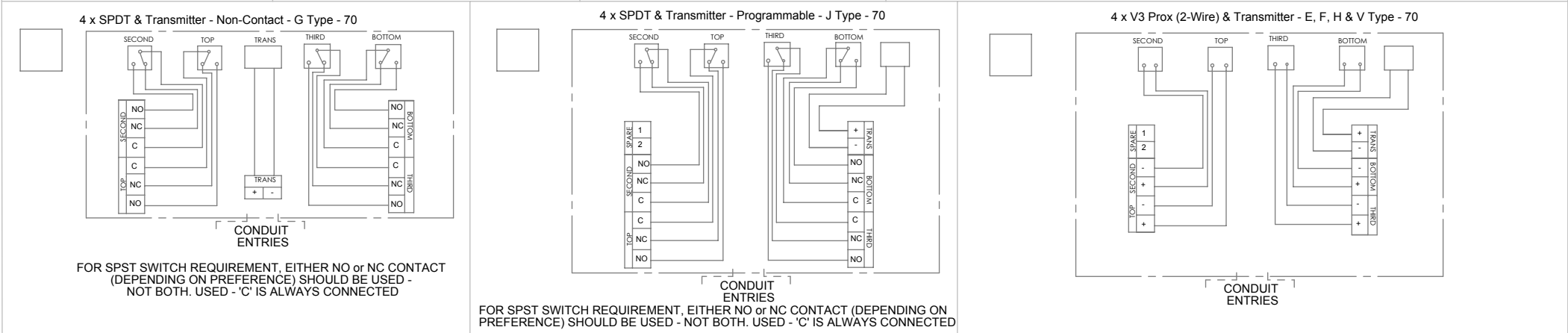
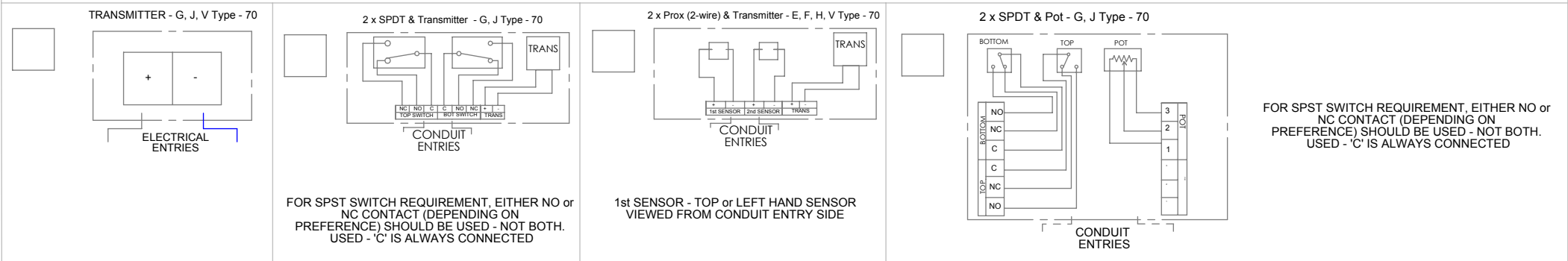

SPECIAL NOTES:

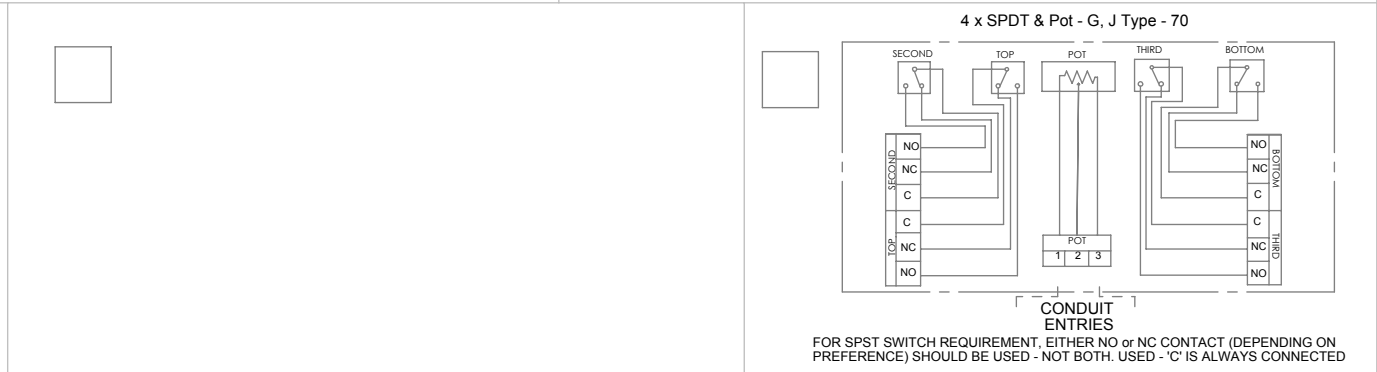

REV	DRAWN	DATE	CHK'D	ECO
	PT	14.8.14		14-2270
A	PI	14.2.17		17-2618
B	PT	1.2.18		18-2692

TITLE:

Installation, Operation & Maintenance AQ - ATEX

This private & confidential drawing is the property of Imtex Controls Limited, Tonbridge, UK and cannot be copied or reproduced without the express written permission of the Company.

Imtex Controls Limited
Deeside - United Kingdom

Website: www.imtex-controls.com

DWG NO. A190317

REV B
STATUS R
A4

SHEET 5 OF 5