

Installation, Operating and Maintenance Instructions

Model	SRX
Hazardous Classification	Exd (Flameproof)
Regional Certification	ATEX / IECEx / UKCA

Instructions

Type SRX Valve Position Monitors are designed to provide high accuracy feedback of valve position to plant control systems. These instructions outline the requirements for ensuring a long and trouble free service life from the monitors.

Installation – Mounting

(refer to diagram below)

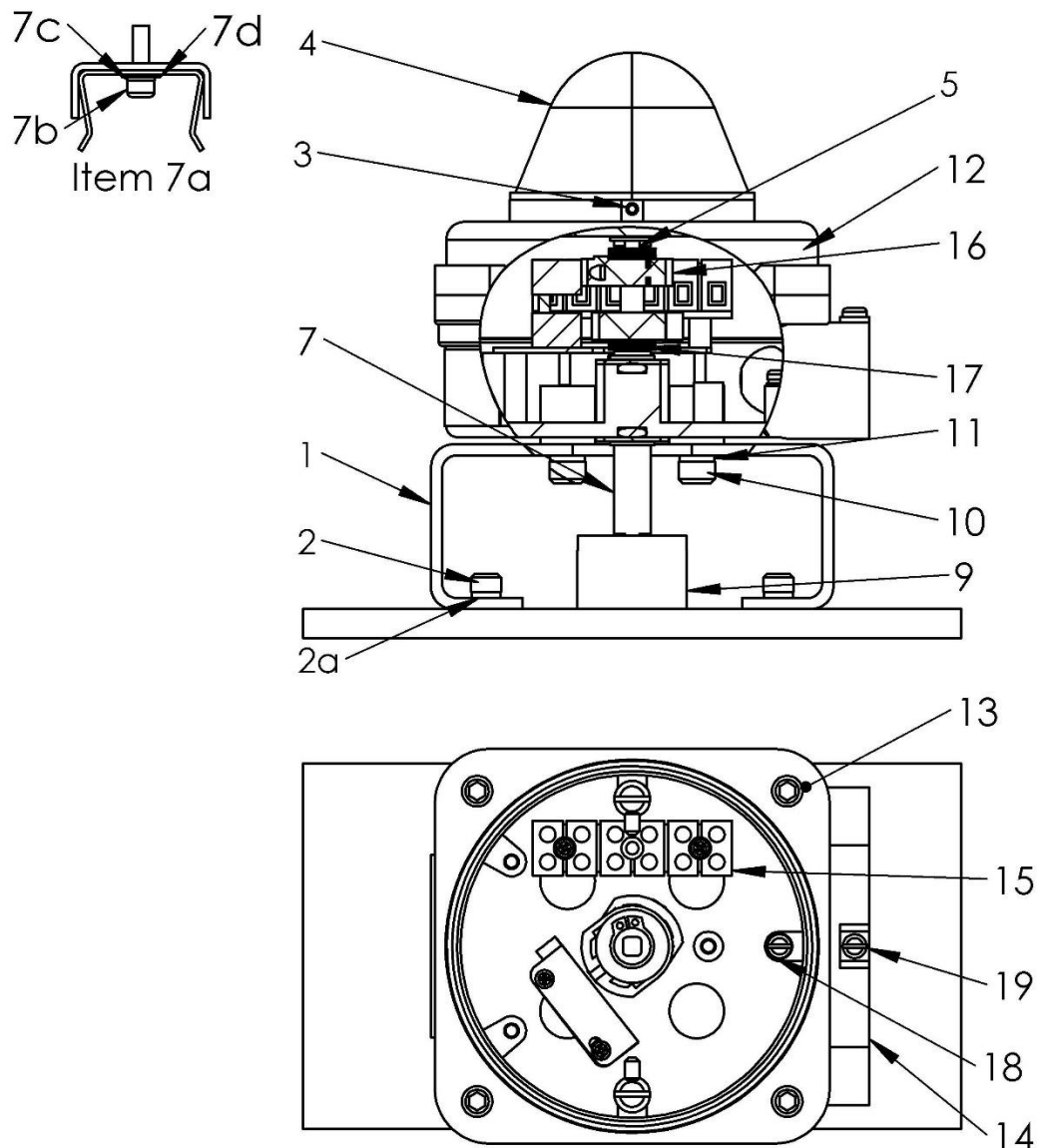

Installation, Operating and Maintenance Instructions

Model	SRX
Hazardous Classification	Exd (Flameproof)
Regional Certification	ATEX / IECEx / UKCA

Attach mounting plate (1) to the actuator using fasteners (2) and lockwashers (2a) provided with mounting kit (if supplied by Imtex).

Loosen indicator cover set screw (3) and rotate indicator cover (4) to desired viewing angle. Retighten set screw (3).

Fit monitor assembly to actuator ensuring that the NAMUR shaft (7) engages the shaft of the actuator (9). If a torque coupler (7a) is used instead of the NAMUR shaft on Non-NAMUR actuators, ensure this is securely fitted to the underside of the monitor using the screw, flatwasher and lockwasher supplied (7b/7c/7d) before fitting over the flats on the actuator shaft (9).

Secure the assembly using the screws (10) and lockwashers (11) provided with the mounting kit.

Fine tune the indicator cover (4) by loosening set screw (3). Retighten set screw when completed.

Operate the actuator to ensure proper alignment between monitor and actuator. Eccentricity of the shaft must not exceed 0.25mm. If it should be necessary, re-align monitor by loosening mount screws (10). Retighten screws when satisfied with alignment.

Installation - Wiring & Switch Setting

Once the monitor is fitted to the actuator, remove cover (12) by loosening and removing the 4-off cover lock screws (13).

Bring field wiring into the enclosure via the conduit entries (14) fitted with a suitably certified cable gland. Use blanking plugs to block off any un-used cable entries. NOTE: Suitable IP6x rated cable glands, blanking plugs and thread adaptors must be used to maintain monitor IP rating.

On flameproof enclosures, only certified Exd cable glands, blanking plugs and thread adaptors can be used.

Blanking plugs must not be used with a gland adaptor.

Connect field wiring to the terminals (15) within the enclosure according to the wiring diagram and terminal labelling. Connect earth conductor (which forms part of the supply cable and MUST be at least equal to the size of the phase conductors) to the internal earth point (18). Connect the external earth/equipotential bonding conductor to the monitor using the external earth clamp assembly (19). Conductor should be 4mm² (min).

For monitors fitted with standard cam/spline activated switches/sensors, drive the actuator to the first required indication position and set the bottom switch by lifting and rotating the bottom cam (16). Secure the cam by allowing it to fully re-engage with the spline (17).

Repeat the process for each switch in-turn by lifting/pushing down the appropriate cam, rotating and re-engaging as desired position is reached.

Installation, Operating and Maintenance Instructions

Model	SRX
Hazardous Classification	Exd (Flameproof)
Regional Certification	ATEX / IECEx / UKCA

For monitors with barrel or slotted sensors, or with a transmitter, consult below.

Once completed, verify that indication is as required by fully stroking the actuator. Then refit cover (12) and secure using the 4-off cover lock screws (13). NOTE: The shaft inside the monitor is a 'split' design at the point indicated (5). The top portion which drives the indicator MUST properly engage the bottom portion before re-tightening the screws (13). When fitting the cover, gently 'rotate' it until the shafts engage and the cover drops into place and then rotate the cover to align the cover through holes with the housing. DO NOT APPLY EXCESSIVE FORCE TO FIT THE COVER.

Barrel/Slot Sensor Setting

Drive the actuator to the first required indication position and set the first switch by pushing round the lower metal shim on the shaft (16) to cover the sensor.

Repeat the process for each sensor in-turn by driving the actuator to the indication position and adjusting the appropriate shim to cover the corresponding sensor.

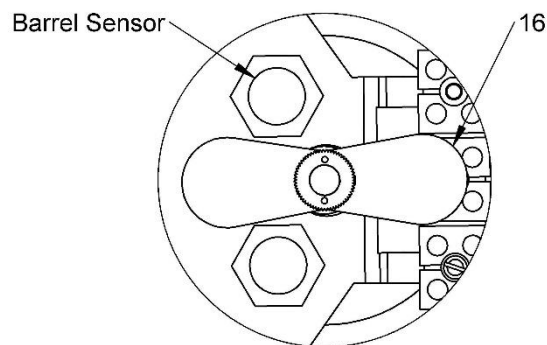

Transmitter Setting

NOTE: The Type SRX Transmitter is factory set to provide position information over a 90 Degree span. Specific information on the method for setting the zero and span for the transmitter option supplied is detailed on the attached Set Up Sheet.

Drive the actuator to the position intended to indicate the 'low' signal. Set the zero point for the transmitter either locally (when available) or using suitable configuration software. Drive the actuator to the position intended to indicate the 'high' signal. Set the span point either locally (where applicable) or using suitable configuration software.

To set the switches/sensors, if supplied, refer to page one of these instructions.

Once completed, verify that indication is required by fully stroking the actuator. Then refit cover (12).

Installation, Operating and Maintenance Instructions

Model	SRX
Hazardous Classification	Exd (Flameproof)
Regional Certification	ATEX / IECEx / UKCA

SPECIAL CONDITIONS FOR CERTIFIED ENCLOSURES

Installation should be carried out by suitably trained personnel to an applicable Code of Practice (eg IEC/EN60079-14).

Only suitably IP and Exd certified and temperature rated cable glands and blanking plugs are permitted for use with certified enclosures.

- ⚠ WARNING - For units operating at +60°C, cable, cable glands or conductors in conduit shall be rated +85°C (minimum).
- ⚠ WARNING – Monitor includes external plastic parts and present Electrostatic Hazard: Clean Only with a Damp Cloth
- ⚠ WARNING - The cable entry temperature rise is the amount stated on the product above ambient - ensure use of suitably temperature rated cable & gland.
- ⚠ WARNING - Do not install on an external source of heating or cooling e.g. by hot/cold air blowing temperature units
- ⚠ WARNING - Locate monitor to prevent propagating brush discharges
- ⚠ WARNING - Monitor should not be opened when energised or an explosive atmosphere may be present.

The cover screws (13) must be loosened before opening and re-tightened before the monitor re-enters service.

SPECIAL CONDITIONS FOR SAFE USE

The maximum specified cover to shaft and base to shaft flamepath gaps are 0.13 mm.

Additional Instructions for Safe Use

The certification for this monitor relies upon the following materials used in its construction:

- Stainless Steel
- EDPM 70 or Viton V700-75 Seals (depending on operating temperatures)

If the equipment is likely to come into contact with aggressive substances, then it is the responsibility of the user to take suitable precautions that prevent it from being adversely affected, thus ensuring that the type of protection provided by the equipment is not compromised. Aggressive substances might be: acidic liquids or gases that attack Stainless Steel, or direct and prolonged contact with some Hydrocarbons that could affect the seals. Regular checks/inspections should be carried out if aggressive substances are present.

Installation, Operating and Maintenance Instructions

Model	SRX
Hazardous Classification	Exd (Flameproof)
Regional Certification	ATEX / IECEx / UKCA

Maintenance

The Type SRX requires no servicing during normal working life, if installed correctly. However, it is advisable to check mounting screws/bolts, o-rings and terminal wiring for signs of loosening or corrosion as part of the routine plant maintenance to ensure continued operation. Ensure safety warnings are observed during maintenance.

Inspection & maintenance to certified flameproof enclosures to be carried out by suitably trained personnel with applicable code of practice (eg IEC/EN60079-17). Repairs to Type SRX flameproof enclosures are not permitted. Please consult factory.

Certification

Exdb IIB T6 Gb and Ex tb IIIC T85°C Db - IP6X

Tamb = -40°C to +60°C

Referenced Standards

The following standards have been referred to in these instructions and are applicable to the use of this product when used in an environment where an explosive atmosphere may be present:



IEC 60079-0:2017 7th Ed
IEC60079-1:2014 7th Ed
IEC 60079-31:2013 2nd Ed
EN60079-0:2012
EN60079-1:2014
EN60079-31:2014
EN IEC 60079-0:2018

Installation, Operating and Maintenance Instructions

Model	SRX
Hazardous Classification	Exd (Flameproof)
Regional Certification	ATEX / IECEx / UKCA

Product Markings

The label on the monitor should be one of the two shown below:

IEC Cert No: IECEx SIR 10.0106X	CE	UK CA	 <small>COMMUNICATING WITH VALVES</small> Deeside, Flintshire - UK www.imtex-controls.com
ATEX Cert No: SIRA 10ATEX 1219X			
UKCA Cert No: CSAE 21UKEX1449X			
Model: SRX			
Serial No: <input style="width: 150px;" type="text"/>	IP66 / 67		<input style="width: 50px;" type="text"/>
Max Permissible Power Dissipation in Enclosure: <input style="width: 80px;" type="text"/> Watts	Exdb IIB T6 Gb Ex tb IIIC T85°C Db IP6X Tamb = -40°C to +60°C		
 WARNING! ELECTROSTATIC HAZARD - CLEAN ONLY WITH DAMP CLOTH WARNING! DO NOT OPEN WHEN ENERGISED OR WHEN AN EXPLOSIVE ATMOSPHERE MAY BE PRESENT WARNING! CABLE TEMPERATURE MAY EXCEED 70°C - CABLING TO BE SUITABLE			

NOTE: The year of manufacture of the monitor can be obtained from the last 2 digits of the serial number.

Installation, Operating and Maintenance Instructions

Model	SRX
Hazardous Classification	Exd (Flameproof)
Regional Certification	ATEX / IECEx / UKCA

Cable Entries

The number and type of cable entry on the Monitor can be determined by reference to the 7th digit of the Format 1 part number or the 5th digit of the 2nd block in Format 2 part number.

For example, in the following part numbers –

Format 1 – SRX25S5SR-IOO

the 7th digit is a '5' which corresponds to the monitor having 2 off M20 x 1.5 cable entry. Refer to table below for details.

DIGIT	ENTRIES SUPPLIED
5	(2) M20 X 1.5
B	(2) ½" NPT

Format 2 - SRX225000OO-SSOO2SR2-0-WBOO

the 5th digit / 2nd block is a '2' which corresponds to the monitor having 2 off M20 x 1.5 cable entry. Refer to table below for details.

DIGIT	ENTRIES SUPPLIED	DIGIT	ENTRIES SUPPLIED
1	(1) M20 x 1.5	A	(1) ½" NPT
2	(2) M20 x 1.5	B	(2) ½" NPT

NPT Threads conform to ANSI/ASME B1.20.1 and shall be made up wrench tight.

Metric Thread tolerance to ISO 965-1 and ISO 965-3

Installation, Operating and Maintenance Instructions

Model	SRX
Hazardous Classification	Exd (Flameproof)
Regional Certification	ATEX / IECEx / UKCA

Electrical Characteristics

Format 1 – SRX**XX**xxxx-xxx

Format 2 – SRX**XX****XX**xx-xxxxxxxx-x-xxxx

Mechanical Switch w/ Silver Contacts	
Function No	16 & 55 (format 1) / 16 (format 2)
Electrical Ratings	10.0A @ 125/250VAC 0.5A @ 125VDC
Temperature Range	-40 to +85°C
Operating Life	400, 000 Cycles
Not Recommended for circuits operating under 20mA @ 24VDC	

Mechanical Switch w/ Gold Contacts	
Function No	17 & 56 (format 1) / 17 (format 2)
Electrical Ratings	1.0A @ 125VAC 0.5A @ 30VDC
Temperature Range	-40 to +85°C
Operating Life	100, 000 Cycles
Recommended for use in 24VDC computer input circuits	

Reed Switch (A140077)	
Function No	25 & 58 (format 1) / 25 (format 2)
Electrical Ratings	0.5A (switching) / 1.0A (Steady State) @ 120V Max 10W/VA Max
Temperature Range	-50 to +85°C
Operating Life	5,000, 000 Cycles
Where reed switches are installed at the end of long cable runs, it is the responsibility of the installer to ensure suitable precautions are taken to ensure cable capacitance does not induce premature switch failure. Consult Imtex for further information	

Installation, Operating and Maintenance Instructions

Model	SRX
Hazardous Classification	Exd (Flameproof)
Regional Certification	ATEX / IECEx / UKCA

Reed Switch w/ Choke (A140077-SU)	
Function No	25 & 58 (format 1) / 40 (format 2)
Electrical Ratings	0.15A @ 125VAC / 30VDC 680 μ H 10 Ohms
Temperature Range	-50 to +85°C
Operating Life	5,000, 000 Cycles
Where a reed switch with choke is used, the installer must carry out an ignition capability assessment of the full circuit (in accordance with EN60079-11:2012, Annex A).	

Tungsten Reed Switch (A140088)	
Function No	25 & 58 (format 1) / 30 (format 2)
Electrical Ratings	Max Current: 3.0A Max Power 100W/VA Max Min Power: 2 Watts
Temperature Range	-40 to +85°C
Operating Life	5,000, 000 Cycles
Not Recommended for circuits operating under 90mA @ 24VDC	

V3 NAMUR Proximity Sensor	
Function No	42 & 52 (format 1) / 42 (format 2)
Electrical Ratings	Target Present – Current < 1mA Target Absent – Current > 3mA 5 to 25VDC (Nominal 8VDC)
Temperature Range	-25 to +100°C
Operating Life	Unlimited Cycles
Use with intrinsically safe repeater barrier. Namur sensors fully conform to EN60947-5-6 (VDE0660 Part 212) standard.	

Cylindrical/Slot NAMUR Proximity Sensor	
Function No	43 & 53 (format 1) / 43 & 47 (format 2)
Electrical Ratings	Target Present – Current < 1mA Target Absent – Current > 3mA 5 to 25VDC (Nominal 8VDC)
Temperature Range	-50 to +100°C (sensor dependent)
Operating Life	Unlimited Cycles
Use with intrinsically safe repeater barrier. Namur sensors fully conform to EN60947-5-6 (VDE0660 Part 212) standard.	

Installation, Operating and Maintenance Instructions

Model	SRX
Hazardous Classification	Exd (Flameproof)
Regional Certification	ATEX / IECEx / UKCA

Non-Contact Transmitter	
Function No	70 (format 1) / 70 & 71 (format 2)
Electrical Ratings	12 to 28 VDC R < (U-9) / 0.02 Linearity < 1% FS Repeatability < 0.36°
Temperature Range	-40 to +85°C
Operating Life	Unlimited Cycles

Programmable Transmitter	
Function No	70 (format 1) / 72 (format 2)
Electrical Ratings	8 to 30 VDC Internal Consumption: 25mW to 0.8W Voltage Drop: 8VDC Warm Up Time: 5 min Min Response Time: 0.33s (model dependent) Linearity < 1% FS Repeatability < 0.36°
Temperature Range	-40 to +85°C
Operating Life	1, 000, 000 Cycles

Analogue Transmitter – PCB Style	
Function No	70 (format 1) / 74 (format 2)
Electrical Ratings	12 to 40 VDC R < 700 ohms @ 24VDC Linearity ± 0.85°
Temperature Range	-40 to +85°C
Operating Life	1, 000, 000 Cycles

Potentiometer	
Function No	70 (format 1) / 74 (format 2)
Electrical Ratings	Resistance: 10k ohms Output Smoothness: 0.1% (Max) Electrical Travel: 340° ± 3° Power Rating: 1.0W @ 70°C Tolerance: ± 20% Linearity: ± 2.0%
Temperature Range	-40 to +85°C
Operating Life	1, 000, 000 Cycles

Installation, Operating and Maintenance Instructions

Model	SRX
Hazardous Classification	Exd (Flameproof)
Regional Certification	ATEX / IECEx / UKCA

Terminal Wiring

Wiring connection details are provided in the unit, with detail of the assigned connection displayed on the terminal block.

Further Details

For further information on this product contact:

Imtex Controls Ltd
Unit 4, Tenth Avenue
Deeside Industrial Estate
Deeside, Flintshire, CH5 2UA
United Kingdom
www.imtex-controls.com
sales@imtex-controls.com