



## **Installation, Operation and Maintenance Guide**

**Camtorc Actuators – Type S, A or C**

**Operation Principle: Hydraulic**

### **Camtorc Actuators**

**IMTEX Controls Limited**

**Deeside, Flintshire**

**United Kingdom**

**Tel: +44(0)8700-340002**

**Email: [sales@camtorc.com](mailto:sales@camtorc.com)**



## CONTENTS

<b>1</b> 1.1 1.2 1.3	<b>GENERAL INFORMATION</b> Important Safety Information Lubricants and Solvents Tools and Equipment
<b>2</b> 2.1 2.1.1 2.2	<b>INSTALLATION – GENERAL</b> Valve Mounting Alignment Stop Adjustment
<b>3</b>	<b>OPERATION – GENERAL</b>
<b>4</b> 4.1	<b>MAINTENANCE – GENERAL</b> Disassembly / Reassembly Procedures
<b>5</b> 5.1 5.2 5.2.1	<b>STORAGE AND TESTING PROCEDURE</b> General Notes Storage Testing during Storage
<b>6</b> 6.1 6.2 6.3 6.4	<b>TROUBLE SHOOTING</b> Actuator with Problems on Pressure Stroke Actuator with Problems on Spring Stroke Actuator with Hesitant or Jerky Action on Pressure Stroke Actuator with Hesitant or Jerky Action on Spring Stroke



<b>7</b>	<b>TYPE S – SPRING RETURN</b>
7.1	Drawings & Parts Lists
7.2	Installation
7.2.1	Stop Adjustment
7.2.2	Connecting Hydraulic Supply
7.3	Operation
7.3.1	Principle of Operation
7.3.1.1	Type S – Double Acting
7.3.1.2	Type S – Spring Return
7.4	Maintenance
7.4.1	Disassembly
7.4.1.1	Spring Cylinder Removal
7.4.1.2	Spring Cylinder Disassembly
7.4.1.3	Body Disassembly
7.4.1.4	Hydraulic Cylinder Disassembly
7.4.2	Reassembly
7.4.2.1	General Notes
7.4.2.2	Hydraulic Cylinder Reassembly
7.4.2.3	Body Reassembly
7.4.2.4	Spring Cylinder Reassembly

<p><b>8</b></p> <p>8.1</p> <p>8.2</p> <p>    8.2.1</p> <p>    8.2.2</p> <p>        8.2.2.1</p> <p>        8.2.2.2</p> <p>8.3</p> <p>    8.3.1</p> <p>        8.3.1.1</p> <p>        8.3.1.2</p> <p>8.4</p> <p>    8.4.1</p> <p>        8.4.1.1</p> <p>        8.4.1.2</p> <p>        8.4.1.3</p> <p>        8.4.2.4</p> <p>    8.4.2</p> <p>        8.4.2.1</p> <p>        8.4.2.2</p> <p>        8.4.2.3</p> <p>        8.4.2.4</p> <p>        8.4.2.5</p>	<p><b>TYPE C – DOUBLE ACTING &amp; SPRING RETURN</b></p> <p>Drawings &amp; Parts Lists</p> <p>Installation</p> <p>    Stop Adjustment</p> <p>    Connecting Hydraulic Supply</p> <p>        Type C – Double Acting</p> <p>        Type C – Spring Return</p> <p>Operation</p> <p>    Principle of Operation</p> <p>        Type C – Double Acting</p> <p>        Type C – Spring Return</p> <p>Maintenance</p> <p>    Actuator Disassembly</p> <p>        Cylinder Disassembly from Body</p> <p>        Disassembly of Hydraulic Cylinder</p> <p>        Body Disassembly</p> <p>        Spring Cylinder Disassembly</p> <p>    Reassembly</p> <p>        General Notes</p> <p>        Body Reassembly</p> <p>        Spring Cylinder Reassembly</p> <p>        Cylinder Reassembly</p> <p>        Cylinder Reassembly to Body</p>
<p><b>9</b></p> <p>9.1</p> <p>9.2</p>	<p><b>SUBMERSIBLE ACTUATORS</b></p> <p>Installation</p> <p>Maintenance</p>
<p><b>10</b></p> <p>10.1</p> <p>10.2</p>	<p><b>ATEX &amp; UKCA INFORMATION</b></p> <p>Referenced Standards</p> <p>Product Labelling</p>
<p><b>APPENDIX</b></p>	<p><b>DRAWINGS &amp; PARTS LISTS REFERENCED IN MAIN DOCUMENT</b></p>



## **1. GENERAL INFORMATION**

### **1.1 - Important Safety Information**

A competent technician who is familiar with this type of equipment must carry out all instructions within this manual.

Prior to commencing any work on a Camtorc actuator, it must be confirmed that the actuator has been isolated from the hydraulic supply and that the actuator has been fully vented.

Ensure that proper and approved methods are employed for lifting or handling the actuator.

Document FSM-001 (supplied separately) details additional requirements that must be observed to ensure the actuator complies with its functional safety requirements and it can be used within a Safety Instrumented System (SIS).

### **Special Conditions for Safe Use**

Because the stored energy in the spring could be an ignition source for an explosion, the preloaded spring assembly within a spring return actuator shall only be dismantled in a safe area when doing maintenance.

### **1.2 - Lubricants & Solvents**

The grease used in the mechanisms of Camtorc Actuators is DUCKHAMS ADMAX 27 L2 NLGI No 2 LITHIUM BASE GREASE or any commercially available equivalent.

The hydraulic oil used to apply pressure to the actuator and lubricate all seals during assembly is a proprietary mineral based lubricating oil or silicone oil.

Proprietary solvents may be used for cleaning the various actuator components provided every trace is removed before seals are fitted. **DO NOT ALLOW SOLVENTS TO COME INTO CONTACT WITH ANY ELASTOMERIC SEALS, PTFE BEARINGS or WEAR PADS.**

### **1.3 - Tools and Equipment**

The following tools and equipment will be required for the servicing procedures in this manual. This list is given as a minimum requirement;

- Various Allen Keys
- Various Spanners
- Hammer
- Mallet – Copper/Hide or Nylon faced



## 2 – INSTALLATION - GENERAL

It is the responsibility of the installer to ensure that the actuator supplied is suitable for the application and operating environment into which it is fitted. Particular attention should be paid to installations where potentially hazardous environments exist. Full details of the operating characteristics and approvals applicable to the Camtorc actuator can be found on the actuator name plate. Do not hesitate to contact the Camtorc engineers with any application questions you may have.

Actuators are factory supplied with Red PVC Dust plugs fitted in the Supply Ports (when actuator is supplied without a control system) and Exhaust Ports (refer to J100462 & J100463). **Please ensure that the Red PVC Dust Plugs are removed from the Exhaust Ports and replaced with the Breathers supplied loose with Actuator.**

Unless otherwise stated, it is assumed that the process valve will be assembled into a horizontal pipeline and that the actuator will be connected to a vertical, upright valve stem. In the event that the process valve is mounted into a vertical pipeline or the valve stem is not in a vertical upright position, it is always recommended that the weight of the actuator assembly is suitably supported by additional framework to prevent potential side loading on the valve stem.

### 2.1 - Valve Mounting

- The valve is mounted to the actuator via a suitable mounting bracket and coupling.
- Ensure that the valve and actuator are in the same end position before commencing mounting (ie Valve Closed / Actuator in Closed Position – normally, actuators close clockwise)
- Install the Actuator to the valve and note the mounting hole alignment relative to the Actuator mounting holes.

#### 2.1.1 - Alignment

If the mounting holes are not in alignment, the stop screws will require adjusting (see section on adjusting the stop screws for each type of actuator). This adjustment must be performed by applying supply pressure to the actuator to alter its rotation, followed by adjustment of the Stop Screw to the new position. Repeat this procedure as often as necessary in order to achieve the required alignment



**NOTE : THE AMOUNT OF ACTUATOR ROTATION MUST ALWAYS BE ADJUSTED USING AIR PRESSURE FOLLOWED BY RE-POSITIONING OF THE STOP SCREW. NEVER USE THE STOP SCREW ALONE AS A JACK SCREW AS DAMAGE MAY RESULT**

## 2.2 - Stop Adjustment

Actuators are supplied de-energised in the fail position (if applicable) with stops factory set to provide 90 degree rotation. Once the actuator has been mounted to the valve, the stops can be fine-tuned as detailed in the specific information relating to each type of actuator.

## **3 – OPERATION - GENERAL**

- It is the responsibility of the plant operator to ensure that Camtorc actuators are operated in a safe manner in compliance with all applicable standards.
- Suitable personal protection should be provided to any personnel working on and around Camtorc actuators.
- Camtorc actuators should only be operated using non-corrosive, non-explosive, clean and filtered fluids.
- The minimum and maximum operating temperatures and pressures detailed on the actuator nameplate should be observed AT ALL TIMES for safe operation.
- As Camtorc actuators have moving parts, an installed actuator should be inspected routinely to ensure it is clean and free of any dust build up (potential ignition hazard).
- All Camtorc actuators are fully lubricated during assembly for life (nominally 500,000 cycles, subject to operating conditions). However, it is recommended that seals are replaced at intervals no greater than every five years as part of routine maintenance (procedure for changing seals is detailed in the Maintenance section below).



## 4 – MAINTENANCE – GENERAL

**Expected Product Life:** 20 Years (Low Demand) or 500,000 Cycles (High Demand)

Camtorc actuators are designed to provide long and reliable service, if installed correctly. To prolong their effectiveness, the following areas should be inspected periodically:

- Paint Finish – verify that the paint finish is intact and that no metal surfaces (other than stainless steel drive shafts) have become exposed and rusted. If it is decided that some retouching of the paint is required, please contact the MATIC sales office, quoting the actuator serial number, found on the actuator name plate, for details of the paint finish on the actuator.
- Ensure that the exposed moving areas of the actuator (drive shaft and valve coupling) are free from build-up of dust or dirt.
- Ensure that all fittings are tight and leak free. Replace as necessary.
- It is recommended that the actuator seals are replaced periodically (nominally every 2 years but no longer than every 5 years depending on the application and frequency of operation). Details of how to complete this procedure are available under the relevant section of this manual. Seal kits are available from the Camtorc sales office. Only Camtorc seal kits, as purchased from the Camtorc Sales Office, should be fitted. Please quote the actuator serial number, found on the actuator name plate when ordering.
- Should leaks in the actuator be found due to wear, then a full service kit of seals and bearings should be undertaken in accordance with the instructions contained in this manual. Service kits are available from the Camtorc sales office. Only Camtorc Service kits, as purchased from the Camtorc Sales Office, should be fitted. Please quote the actuator serial number, found on the actuator name plate when ordering.

### 4.1 Disassembly / Reassembly Procedures

Refer to specific information on applicable type of actuator.

**WARNING PRIOR TO COMMENCING ANY WORK ON THE ACTUATOR IT MUST BE CONFIRMED THAT THE SUPPLY PRESSURE HAS BEEN DISPERSED AND THAT ELECTRICAL SIGNAL(S) HAVE BEEN DE-ENERGISED**





## 5 - STORAGE & TESTING PROCEDURE

### 5.1 General Notes

This section provides information on preventative maintenance of the Actuator whilst held in storage.

All elastomeric pressure seals, whether Nitrile, EPDM or Viton, can on some occasions “Cold Weld” themselves to their adjacent sealing surfaces when left for extended periods in the static state. When this condition occurs, and the Actuator is pressurised for the first time, the seal is irreparably damaged as small areas of the seal become torn, and remain attached to the cylinder bore due to the shearing action of the piston in the bore. Therefore the intention of this procedure is to ensure that the Actuator remains in the optimum functional state thus requiring minimal commissioning before deployment.

To prevent cold welding, stored actuators should be stroked periodically to exercise the seals. To define an accurate timescale for the performance of this procedure is difficult as it will depend on a number of other influential factors, such as storage temperature, humidity, warehouse or open air storage, period of storage etc. However for the purposes of this procedure, experience has shown that intervals of approximately **Three Months** from ex-works shipment and three monthly intervals thereafter is a suitable period.

For periods of less than three months this procedure is unnecessary and the Actuator will only require commissioning in accordance with other sections of this Manual.

### 5.2 Storage

The ideal storage conditions for the actuator are on a pallet or in a box held in a warehouse. However storage of the palletised or boxed Actuator in the open air is perfectly acceptable provided that all plastic plugs, fitted to the vent and pressure ports, remain in place before and after testing and until commissioning.



The actuator must at all times be stored in such a manner to avoid damage to itself, pipework if fitted, and any ancillary items, i.e. Filter/Regulator, Solenoid Valves, Limit Switches, Electro-hydraulic Positioners etc.

#### 5.2.1 - Testing during Storage

- A clean hydraulic fluid supply will be required with a maximum operating pressure of 150 barg and with some form of local pressure regulation complete with pressure gauge to assist testing.
- Where the Actuator is supplied without ancillary equipment, refer to connection details for connection port sizes in supporting general arrangement drawing. Refer to the contract G.A. Drawing (where applicable) for port connection sizes where the Actuator is supplied with ancillary equipment. This drawing will refer to a connection port(s) on a Filter/Filter Regulator or Solenoid Valve. The drawing will state “HYDRAULIC SUPPLY” and give its physical size along with its type, i.e. 1 /4” NPT (FEMALE).
- Connect the hydraulic supply to the relevant port(s) using a suitable pressure fitting(s).
- Refer to specific contract information, where there are various electrical components fitted, for details regarding electrical control signal requirements. This information can be found on the contract GA drawing (where applicable).
- Remove the plastic plugs fitted to the exhaust ports where necessary. These must be retained for refitting directly after testing. Refer to Operation drawings (J100462 & J100463) for the specific type of actuator for fitting positions of exhaust breathers.

**NOTE** On some occasions, generally due to contract requirements, the exhaust ports will be fitted with some form of breather. If so they should not be removed.



- Gradually apply pressure using the regulator, having energised electrical signals where necessary, in order to stroke the Actuator. The pressure should be regulated such that it is enough to fully stroke the Actuator through 90°. When sufficient pressure has been applied, the actuator will fully stroke. In any event the maximum supply pressure should not exceed the maximum supply pressure stated on the actuator nameplate.
- De-energise the hydraulic and/or electrical signals or connect supply to the other side of the Actuator in order to return the Actuator to the original position.
- Repeat the full stroke for a further five times in order to ensure that the Actuator is performing satisfactorily.



## 6 - TROUBLESHOOTING

### 6.1 - Actuator with Problems on Air Stroke

Problem	Possible Cause	Solution
Actuator will not operate when Hydraulic Pressure is applied?	Supply Pressure is incorrectly set.	Check and adjust Regulator pressure to the correct setting.
	Electrical Signal to a component such as a Solenoid Valve or Electro-Hydraulic Positioner is incorrect or non-existent.	Check for correct electrical signal and reset if necessary.
	Hydraulic leakage over the Pistons.	Check for leakage by looking for signs of Hydraulic fluid exiting the Body Exhaust Port or Hydraulic Return Port. If a leak is detected, replace Seals in offending cylinder in accordance with the relevant section of this manual
	Actuator is incorrectly sized for torque output against the Valve torque.	Check the sizing criteria for both the Actuator and the Valve. The Actuator and Valve manufacturer should be able to advise on the sizing criteria provided their respective Serial Numbers are furnished to them.
	The Valve is jammed	Consult with Valve manufacturer for advice. DO NOT over-pressurise the Actuator as serious Valve damage may result.



## 6.2 - Actuator with Problems on Spring Stroke

Problem	Possible Cause	Solution
Actuator will not operate when Hydraulically and/or Electrically De-energised	Supply Pressure had not Dispersed.	Check that the Pressure and Electrical Signal have been De- energised.
	Vent Ports blocked.	Check vent ports in control component for blockage/dirt and replace or clean as necessary.
	Actuator is incorrectly sized for torque output against the Valve torque.	Check the sizing criteria for both the Actuator and the Valve. The Actuator and Valve manufacturer should be able to advise on the sizing criteria provided their respective Serial Numbers and furnished to them.
	Spring Assembly has failed. <u>This would be highly unlikely.</u>	Check Springs within Spring Assembly. Look for signs of damage to individual Springs within the Spring Nest. Removal of the Spring Nest must be performed in accordance with instructions in the relevant section of this manual. Actuator sizing, as stated above, may still be the more likely cause especially if no visual damage is found. Consult Camtorc for further information.
	The Valve is jammed.	Consult with Valve manufacturer for advice.
	The Actuator is Double Acting	Contact Camtorc with the actuator serial number to verify and for details of Spring Return actuators



### 6.3 - Actuator with Hesitant or Jerky Action on Hydraulic Stroke

<b>Problem</b>	<b>Possible Cause</b>	<b>Solution</b>
Actuator operation is not smooth during Stroke under Pressure.	Insufficient Hydraulic Volume/Flow Rate	Check the supply and HPU system.
	Faulty control components or pipe work.	Check Actuator control system for signs of damage and leakage. Check individual control components and correct function.
	Actuator has been incorrectly serviced or more likely just been serviced	Ensure that Actuator servicing has been conducted exactly in accordance with the relevant section of this manual.

### 6.4 - Actuator with Hesitant or Jerky Action on Spring Stroke

<b>Problem</b>	<b>Possible Cause</b>	<b>Solution</b>
Actuator operation is not smooth during spring stroke	Actuator is incorrectly sized for torque output against the Valve torque.	Check the sizing criteria for both the Actuator and the Valve. The Actuator and Valve manufacturer should be able to advise on the sizing criteria provided their respective Serial Numbers are furnished to them.
	Vent Ports becoming blocked.	Check Vent ports in control component for blockage/dirt and replace or clean as necessary.



## 7 – TYPE S (& A) – DOUBLE ACTING & SPRING RETURN

### 7.1 - Drawings & Parts Lists

Type S – Body – Generic Parts	J100457-HYD
Type S – Spring Cylinder – Generic Parts	J100458
Generic Hydraulic MHS Assembly	J100459
Generic Hydraulic M Assembly	J100460
Type S (and Type A) Actuator – Operation	J100462

### 7.2 - Installation

#### 7.2.1 - Stop Adjustment

Refer to J100459, J100460 & J100458

**NOTE : THE AMOUNT OF ACTUATOR ROTATION IN THE SPRING DIRECTION MUST ALWAYS BE ADJUSTED USING PRESSURE FOLLOWED BY RE-POSITIONING OF THE STOP SCREW. NEVER USE THE STOP SCREW ALONE AS A JACK SCREW AGAINST THE SPRING AS DAMAGE MAY RESULT**

The end stops are located in the hydraulic cylinder assembly (J100459 / 460 – Item 1) – adjusting the spring stroke stop (or one pressure direction on Double Acting Units) - and end of the spring cylinder (J100458 – Item 1) – adjusts the pressure stroke stop (on Spring Return units). End stop adjustment method is the same for all end stop types. For the end stops in the hydraulic cylinder assembly, loosen and remove the End Stop Nut (Item 9) and dowty washer (11). Loosen the Hexagon Nut (10), adjust the End Stop Screw (12) using a suitable allen key. Tighten the nut and replace the dowty washer and the blind nut when correctly set. Follow the same process on the Spring Cylinder if required.

#### 7.2.2 - Connecting Hydraulic Supply

Hydraulic supply should be connected to the Hydraulic Supply Port(s) (see J100462) using a suitable sized fitting (refer to Actuator Dimension Sheet). If the supplied actuator is a 'MHS' unit, ensure the Hydraulic Return Port is connected to the Hydraulic Return line, using a suitable fitting.



## 7.3 - Operation

### 7.3.1 - Principle of Operation

All Camtorc actuators use the same principle to operate a rotary valve or damper. A profiled cam connected to a drive shaft enables linear motion from pistons driven under pressure in a cylinder to be converted to rotary motion ( $90^\circ \pm 2.5$  degrees at either end of travel). The configuration alters depending on the actuator type:

#### 7.3.1.1 – Type A & S – Double Acting

Refer to J100462

Pressure is applied via supply ports – one in either end of the actuator, within the hydraulic cylinder assembly. The Hydraulic Piston drives the cam/shaft mechanism to rotate the valve. When pressure is removed, the Piston stops moving. The second Hydraulic Piston is pressurised to drive in the reverse direction.

#### 7.3.1.2 – Type A & S – Spring Return

Refer to J100462

Pressure is applied via supply port in the end of the hydraulic cylinder assembly Hydraulic Piston. The Hydraulic Piston compresses the spring whilst and drives the cam/shaft mechanism. When pressure is removed, the Spring pushes the cam/shaft mechanism in the other direction.

## 7.4 - Maintenance

**WARNING: BEFORE COMMENCING ANY DISASSEMBLY OF THE ACTUATOR, ENSURE THAT THE ACTUATOR IS ISOLATED FROM THE SUPPLY PRESSURE AND FREE FROM STORED PRESSURE/SPRING FORCE**

Ensure that the actuator is isolated from the pressure supply and any ancillary controls are disconnected/removed from the actuator prior to commencing any work on the actuator. Depending on what maintenance is to be performed, it may be necessary to remove the actuator from its mounting bracket. In this case, the position of the actuator to the mounting kit must be marked with a vertical scribed lines from the base of the actuator to the top of the mounting kit to ensure realignment when reassembling.

Remove Hydraulic Supply pipework from the Actuator.





## 7.4.1 – Actuator Disassembly

### 7.4.1.1 - Spring Cylinder Removal

Refer to Drawing J100458

- Mark the position of the Spring Cylinder Assembly (as represented in J100458) relative to the Actuator Body (as represented in J100457-HYD) before removal. This will ensure the Actuator is reassembled with the correct fail orientation later
- Whilst supporting the Spring Cylinder Assembly, loosen and remove the Hex Head Screws (12) retaining the Spring Cylinder Assembly.
- Remove the Spring Cylinder Assembly from the Actuator Body. NOTE: If the Actuator is an Active/Connected piston design, 4 screws will be connected through the Button (2) onto the Body Piston (5 on J100458). These screws will require removal once the Spring Cylinder Assembly is partially removed before a full removal can occur.



#### 7.4.1.2 - Spring Cylinder Disassembly

Refer to Drawing J100458

**IMPORTANT NOTICE:** The Camtorc Actuator contains a pre-loaded spring assembly. Do not, under any circumstances, attempt to maintain or service this item before reading the following instruction carefully.

- The Spring Cylinder Assembly is held together using Socket Head Capscrews (13) retaining the Intermediate Cap (3) to the Spring Cylinder (1).
- Loosen and remove **ONE** Socket Head Capscrew (13) and replace with suitable studding (see Table below) through the Intermediate cap (3) and out through the reverse side of the Spring Cylinder Flange.
- Place a washer and full nut onto the studding to secure to the reverse side of the Spring Cylinder flange and TIGHTEN.
- Place a second washer and full nut over the studding onto the face of the Intermediate Cap and TIGHTEN
- Repeat for remaining quantity of Socket Head Capscrews/Studding ensuring that the studding is evenly dispersed around the face of the Intermediate Cap (3).

**IMPORTANT DO NOT REMOVE OR REPLACE MORE THAN ONE CAP SCREW AT A TIME**



The following table shows the requirement of studding for dismantling the spring return units:-

Size of Actuator	Type	Qty.	Length	Compressed Spring Force
25SR	M8	4	200	210 Kg,
30SR	M8	4	300	390 Kg.
35SR	M8	4	320	400 Kg.
45SR	M12	4	450	660 Kg.
55SR	M10	4	730	950 Kg.
65SR	M12	6	800	1400 Kg.
75SR	M12	8	1000	1900 Kg.
85SR	M12	8	1000	2400 Kg.
100SR	M12	8	1000	3300 Kg.
110SR	M20	8	1000	4200 Kg.
120SR	M20	8	1000	5000 Kg
140SR	M20	12	1250	5600 Kg.
160SR	M20	12	1250	9150 Kg.

- Once all stud bars and full nuts are in place, evenly loosen the full nuts until the Spring is fully released, then remove all full nuts and lift off the Intermediate Cap (3) and Spring Piston/Stem (4 & 6).
- Loosen and remove Screw (17) from Spring Piston (4) and withdraw Stem (6) from Piston (4) and through Intermediate Cap (3).
- Remove and Discard the Spring Piston O-Ring (11), Slip Strip (19), the End Cap O-Ring on Spring Cylinder side (9), the Stem O-Ring (8), the O-Ring or Dowty Washer under the head of Screw (17) and the Spring Cylinder O-Ring (10).



Note: If the bush in the Intermediate Cap (16) needs replacing, the Cap will have to be returned to Camtorc for refurbishing.

- Loosen and remove End Stop Nut (7) from the Stopscrew (5) located in the end face of the Spring Cylinder (1).

**WARNING: Before performing the step below, measure and record the length the Stop Screw protruding from the face of the Locknut (15) on the stop adjuster. This will ensure that the exact Open and Closed positions of the Actuator, and therefore the valve, are maintained come Actuator/Valve reassembly.**

- Remove and discard the first Dowty Washer (16) from the Stop Screw (5), which is now loose against the face of the Locknut (15).
- Loosen and remove the Locknut (15) from the Stop Screw (5).
- Remove and discard the Dowty Washer (16) from the Stop Screw (5), which is now loose against the face of the Spring Cylinder (1).

Thoroughly clean and inspect all components for evidence of wear or damage. Where necessary obtain spare components from Camtorc before re-assembly.

#### 7.4.1.3 - Body Disassembly

Refer to Drawing J100457-HYD (and initially J100459 & 460)

- Loosen and remove Hexagon Headed Screws (Item 7 – J100459 & 460) and Full Nuts (Item 8 – J100459 & 460) to allow the Hydraulic Cylinder to be removed from the Body (1).
- Loosen and remove Screws (11) from one of the Pistons (4 or 5) and lift out the Piston.

This screw is retained using Loctite™ 601, therefore local heat may be required in the vicinity of the screw area to assist removal

- Withdraw the remaining Piston (4 or 5) and Spacers (3) out through the other end of the Actuator Body.
- Loosen and remove Socket Head Setscrew (10) located in the side of the Cam (6), which is securing the Drive Shaft (2)



- Withdraw the Drive Shaft (2) through Body until Key (9) is free from Cam (6). Remove Key (9) Without Damaging Cam (6) or Bore of the Actuator Body (1).
- Withdraw Shaft (2) and Cam (6) from Actuator Body (1)
- If performing a full service using a service kit supplied by Camtorc, the following should be undertaken (if only replacing seals, only remove and discard the O-Rings detailed below):
- Remove and discard Bushes (8) from Actuator Body (1).
- Remove and Discard Piston O-Rings (14), Slip Strip (15), Wear Pads (7) and Piston Spacer O-Rings (13) from Pistons.
- Remove and Discard O-Rings (12) from Drive Shaft (2)

#### 7.4.1.4 – Hydraulic Cylinder Disassembly

Refer to Drawing J100459 & J100460

- Remove and Discard O-Ring (6) from Hydraulic Cylinder Assembly (1)
- Loosen and remove End Stop Nut (9) from the End Stop Screw (12) located in the Hydraulic Cylinder Assembly (1).

**WARNING: Before performing the step below, measure and record the length the Stop Screw protruding from the face of the Locknut (10) on the stop adjuster. This will ensure that the exact Open and Closed positions of the Actuator, and therefore the valve, are maintained come Actuator/Valve reassembly.**

- Remove and discard the first Dowty Washer (11) from the Stop Screw (12), which is now loose against the face of the Locknut (10).
- Loosen and remove the Locknut (10) from the Stop Screw (12).
- Remove and discard the Dowty Washer (11) from the Stop Screw (12), which is now loose against the face of the Cylinder Assembly (1).
- **SPECIAL STEP FOR MHS UNITS (J100459)** Lift Backup Flange (13) clear of the Hydraulic Cylinder Assembly (1) and remove and discard GACO Seal (14), O-Ring (15) and O-Ring (16).
- Remove Hydraulic Piston (2) from Cylinder Assembly (1). This may require the Piston to be gently pushed via the Cylinder Supply port.



- Remove and discard O-Ring (3), Slip Strip (4) and GACO Seal (5).

Thoroughly clean and inspect all components for evidence of wear or damage. Where necessary obtain spare components from Camtorc before re-assembly.

#### 7.4.2 - Reassembly

**WARNING: DO NOT ALLOW SOLVENTS TO COME INTO CONTACT WITH ANY ELASTOMERIC SEALS, PTFE BEARINGS, OR WEAR PADS.**

##### 7.4.2.1 - General Notes

If not already performed, ensure all seals, and bushes (if full repair is being performed) are removed from the Actuator components, taking care not to damage their individual sealing surfaces.

Before commencing the reassembly of the Actuator, all components must be inspected and cleaned. Particular attention must be paid to sealing surfaces and screw threads.

To ease reassembly, lubricate all seals using a light mineral oil.

##### 7.4.2.2 – Hydraulic Cylinder Reassembly

Refer to Drawings J100459 & J100460

- Fit O-Ring (3), Slip Strip (4) and GACO Seal (5) onto Hydraulic Piston (2)
- Fit Hydraulic Piston (2) into Cylinder Assembly (1). Care should be taken that the piston is fitted in the correct orientation (refer to Drawing) and without damaging the seals.

**WARNING: Before performing the step below, ensure that the Stop Screw (12) is refitted with the same length protruding from Nut (10) as it was prior to disassembly.**

- Fit Stop Screw (12) and first Dowty Washer (11) which will now be loose against the face of the Cylinder Assembly (1).
- Fit the Locknut (10) on the Stop Screw (12).
- Fit the second Dowty Washer (11) on the Stop Screw (12). It will be loose against the face of the Locknut (10).
- Fit End Stop Nut (9) to End Stop Screw (12)



- **SPECIAL STEP FOR MHS UNITS (J100459)** Fit GACO Seal (14), O-Ring (15) and O-Ring (16) onto Backup Flange (13) and locate on Hydraulic Cylinder Assembly (1)
- Fit O-Ring (6) onto Hydraulic Cylinder Assembly (1)

#### 7.4.2.3 - Body Reassembly

Refer to Drawings J100457-HYD

- Install Bushes (8) into Actuator Body (1).
- Install O-Rings (12) onto the Drive Shaft (2).
- Install Cam (6) inside bore of the Actuator Body (1). Insert Drive Shaft (2) into Actuator Body (1) and Cam (6) until Key (9) is able to be located into the Drive Shaft (2).

Note: Do not Mark or Damage bore of the Actuator

- Install Key (9) into Drive Shaft (2) and proceed to install the Drive Shaft (2) through the Cam (6) and in to the opposite side of Actuator Body (1).
- Install Socket Head Setscrew (10) into Cam (6) and secure to Drive Shaft (2).
- Apply a layer of grease (approximately 12mm. thick) to the periphery and surface of the Cam
- Install O Ring (14), Slip Strip (15) and Wear Pad (7) to both Pistons (4 & 5).
- Install Spacers (3), 2-off O-Ring (13) and 2-off Socket Head Countersink Screw (11) onto the Piston (4).

The Socket Head Countersink Screw is retained using Loctite™ 601,

- Install the Piston (4) complete with Spacers (3) into one end of the Actuator Body (1) with the Spacers positioned either side of the Cam (6). NOTE: Ensure that the Piston is inserted on the same side of the Actuator Body (1) from which it was initially removed. Failure to do so may prevent the Actuator operating correctly when re-commissioned.
- Install the second Piston (5) into the Actuator Body (1) so that its central mounting holes are located over the Spacers (3) internal screw threads.



- Install 2-off O-Ring (13) to the counterbores located in the centre of the Piston (5).  
NOTE: if this Piston is a Non-Pressure type with 4 x Threaded Holes arranged around its centre, there will not be a recess for the 2 x O-Ring described here. They are not required on this variant.
- Install 2-off Socket Head Countersink Screw (12) through the counterbores located in the centre of the Piston (5) and fasten to the Spacers (3).

The Socket Head Countersink Screw is retained using Loctite™ 601,

NOTE: The next step should be repeated twice if the actuator being assembled is Double Acting.

- Install the Hydraulic Assembly (as drawings J100459 & 460) onto Actuator Body (1) and secure using Hexagon headed screw (Item 5 on J100459 & 460) and Full Nut (Item 6 on J100459 & 460)

#### 7.4.2.4 - Spring Cylinder Reassembly

Refer to Drawings J100458

- Install the O-Ring (8) to the central bore of the Intermediate Cap (3).
- Locate the smallest spigot diameter face on the Intermediate Cap (3) and carefully install the Stem/Button (6, 2) through the central bore of the Intermediate Cap (3).
- Install the O-Ring (10) to the largest Spigot Diameter of the Intermediate Cap (3).
- Install the Stem (6) into the mating recess in the Spring Piston (4) and secure from other side with the Screw (17). Ensure the O-Ring or Dowty Washer (18) is in place under the head of the Screw (17) as it is assembled.

Note: The screw is retained using Loctite™ 601

- Install the O-Ring (11) and Slip Strip (19) to the outside of the Spring Piston (4).
- Locate Sub Assembly of the Intermediate Cap (3), Spring Piston (4) and Stem (6) onto the top of the Spring Nest (20) within the Spring Cylinder (1).





- Install suitable studding through the Intermediate Cap (3) and out through the reverse side of the Spring Cylinder Flange. Place washer and full nut onto the studding to secure to the reverse side Spring Cylinder Flange and TIGHTEN.
- Place a second washer and full nut over the studding on the Intermediate Cap side and screw down HAND TIGHT.
- Once all stud bars and full nuts are in place, evenly tighten the full nuts until the Intermediate Cap (3) is flush against the Spring Cylinder (20) Flange. Remove studding and replace with Socket Head Capscrew (21).

**IMPORTANT: DO NOT REMOVE OR REPLACE MORE THAN ONE STUD BAR WITH SOCKET HEAD CAP SCREW AT A TIME**

- Install Dowty Washer (16) to Stop Screw (5) located in the face of the Spring Cylinder (20).
- Install Locknut (15) to Stop Screw (5).

**WARNING** : Ensure that the measurements of the Stop Screw, recorded previously are accurately reset before tightening the Locknut (15). This will ensure that the Actuator's original Open and Close positions are maintained.

- Install the second Dowty Washer (16) to Stop Screw (5)
- Install the End Stop Nut (7) to the Stop Screw (5).

### Spring Cylinder Replacement

Refer to Drawing J100458 & J100457-HYD

- Install Spring Cylinder Assembly (depicted in J100458) to the Actuator Body (depicted in J100457-HYD) using the marked position relative to the Actuator Body established on disassembly.
- Install Screws (J100458 - 12) through the face of the mounting flange of the Body (J100457 - 1) and into Spring Cylinder Assembly.



## **8 – TYPE C– DOUBLE ACTING & SPRING RETURN**

### 8.1 - Drawings & Parts Lists

Type C – Body – General Parts Assembly (Sizes 30 to 100)	J100444
Type C – Hydraulic Cylinder – General Parts Assembly	J100455
Type C – Spring Cylinder – General Assembly	J100454
Type C – Hydraulic Actuator – Principle of Operation	J100463

### 8.2 - Installation

#### 8.2.1 - Stop Adjustment

Refer to J100444

**NOTE : THE AMOUNT OF ACTUATOR ROTATION IN THE SPRING DIRECTION MUST ALWAYS BE ADJUSTED USING HYDRAULIC PRESSURE FOLLOWED BY RE-POSITIONING OF THE STOP SCREW. NEVER USE THE STOP SCREW ALONE AS A JACK SCREW AS DAMAGE MAY RESULT**

The stop adjustment for the Type C are the same for all configurations from actuator size Cx30 to Cx100. For actuator size Cx150, the end stops are positioned in the pressure and spring cylinder assemblies and are set in the same way as the Type S actuator (see section 7.2.1 above).

The following end stop adjustment instructions relate to the Cx30 to Cx100 actuator models only.

The end stops are located in the actuator body (1). When viewed from above with the stops in the 11 O’Clock and 1 O’Clock positions, the left hand stop adjusts the clockwise direction. To adjust end stops, loosen and remove the end stop nut (30). Loosen the hexagon lock nut (26), adjust the end stop screw (16) using a suitable allen key. Tighten the lock nut and replace the blind hexagon nut.



## 8.2.2 - Connecting Hydraulic Supply

Refer to J100463

### 8.2.2.1 - Type C – Double Acting

Hydraulic supply should be connected to the Supply Port(s) in accordance with the Cylinder arrangement of the actuator (see J100463). Suitably sized fitting(s) should be used – refer to the specific General Arrangement drawing for the Actuator for details of the correct port size. For double cylinder units (as shown on J100463) each operation direction has 1 or 2 supply ports, depending on the desired torque for the actuator.



#### 8.2.2.2 - Type C – Spring Return

Hydraulic supply should be connected to the Hydraulic Cylinder Supply Port (see J100463) Suitably sized fitting(s) should be used – refer to the specific General Arrangement drawing for the Actuator for details of the correct port size.

### 8.3 - Operation

#### 8.3.1 - Principle of Operation

All Camtorc actuators use the same principle to operate a rotary valve or damper. A profiled cam connected to a drive shaft enables linear motion from pistons driven under pressure or by spring force in a cylinder to be converted to rotary motion ( $90^\circ \pm 2.5$  degrees at either end of travel). The configuration alters depending on the actuator type:

##### 8.3.1.1 - Type C – Double Acting

Refer to J100463

Pressure is applied via supply ports (connected as detailed above) onto one side of the piston(s) running within cylinder(s) attached to the main body housing, depending on the desired direction of travel. This enables the cam/shaft mechanism of the actuator to drive in both directions, depending on which side of the piston is pressurised.

##### 8.3.1.2 - Type C – Spring Return

Refer to J100463

Pressure is applied via supply ports (connected as detailed above) onto the hydraulic piston running within the hydraulic cylinder attached to the main body housing. The force of the piston drives the cam/shaft mechanism of the actuator and compresses the spring. When pressure is removed, the spring pushes the spring piston and, in turn, the cam/shaft mechanism in the other direction.

### 8.4 - Maintenance

**WARNING: BEFORE COMMENCING ANY DISASSEMBLY OF THE ACTUATOR, ENSURE THAT THE ACTUATOR IS ISOLATED FROM THE SUPPLY PRESSURE AND FREE FROM STORED PRESSURE/SPRING FORCE**

Ensure that the actuator is isolated from the pressure supply and any ancillary controls are disconnected/removed from the actuator prior to commencing any work on the actuator. Depending on what maintenance is to be performed, it may be necessary to remove the



actuator from its mounting bracket. In this case, the position of the actuator to the mounting kit must be marked with a vertical scribed lines from the base of the actuator to the top of the mounting kit to ensure realignment when reassembling.

Remove Hydraulic Supply pipework from the Actuator.

#### 8.4.1 – Actuator Disassembly

##### 8.4.1.1 - Cylinder Disassembly from Body

The disassembly of all variants of the Type CS & CX, whether single or double cylinder, Double Acting or Spring Return is the same.

**WARNING: ON SPRING RETURN MODELS, DO NOT ATTEMPT TO DISASSEMBLE THE SPRING CYLINDER BEFORE READING AND APPLYING THE METHODOLOGIES DETAILED LATER IN THIS DOCUMENT**

NOTE: IF CHANGING THE SEALS IN THE HYDRAULIC CYLINDER, THIS CAN BE DONE WITH THE CYLINDER STILL ATTACHED TO THE ACTUATOR BODY. REFER TO INSTRUCTIONS ON THE DISASSEMBLY OF THE HYDRAULIC CYLINDER (10.4.1.1.1)

#### **Refer to J100444 and CS150-BODY-IOM**

- On spring return models, remove the Spring Cylinder prior to the Hydraulic Cylinder.
- Remove Cover Plate (3)
- If Connector Plate (28) is attached to Button (19), remove 4 x screw or nut on Cx150 (15) to 'free' Connector Plate.
- Ensuring the cylinder to be removed is supported, loosen and remove 4 x screw (18)
- The Cylinder can now be removed from the Body. It may be necessary to remove the Connector Plate (28) from the Stem on the Cylinder (refer to appropriate Assembly drawing) by loosening and removing screw (25). On Cx150 actuators, the stem is screwed straight into the connecting plate
- Remove and discard the Cylinder Gasket (20)

The Hydraulic Cylinder can be disassembled without the need to remove the actuator from the valve. This enables seals to be changed easily.

#### 8.4.1.2 - Disassembly of Hydraulic Cylinder

Refer to J100455

- Loosen and remove Nuts (6) in End Cap (2).
- Lift End Cap (2) clear of the Hydraulic Cylinder (3) and discard (10) and Back Up Ring (12) in End Cap
- Remove Cylinder (3).Discard O-ring (11) on Intermediate cap (1)
- If Hydraulic Piston (8) is not attached to Stem (5), it will need to be pushed out of the Hydraulic Cylinder (3)
- Remove and Discard Piston O-ring (10), Back Up Ring (12) and Slip Strip (9) on Hydraulic Piston (8).
- Remove Stem (5) from Intermediate Cap (1) and remove and discard O-Ring (7).

#### 8.4.1.3 - Body Disassembly

Refer to Drawing J100444 and CS150-BODY-IOM.

Where 2 Item numbers are quoted for reference on a part in the drawings, the first number relates to J100444 and the second relates to CS150-BODY-IOM.

NOTE: The removal of stop screws from the body step detailed below only applies to Cx30 to Cx100 actuators

- Loosen and remove End Stop Nuts (30) from the Stop Screws (16) located in the Actuator Body (1).

**WARNING: Before performing the step below, measure and record the length the Stop Screw (16) protruding from the face of the Locknut (26) on the stop screw. This will ensure that the exact Open and Closed positions of the Actuator, and therefore the valve, are maintained come Actuator/Valve reassembly.**

- Loosen and remove the Locknuts (26) from the Stop Screws (16).
- Remove and discard the Dowty Washers (23) from the Stop Screws (16), which is now loose against the face of the Body (1).



- Loosen and remove Cover Screws (5) and remove Cover Plate (3). Remove and discard Cover Gasket (21).
- Loosen and remove Top Plate Screws (31 / 27) and remove Top Plate (10) from Cover (3). Remove and discard Top Plate Gasket (22) and Bush (12).
- Loosen and remove Screws / Nuts (15) in Connection Plates (28). This will allow the Cam Spacers (9) to be removed and Buttons (19) to slide apart. Remove and discard Wear Pad (7) from Buttons (19).

These screws are retained using Loctite™ 601, therefore local heat may be required in the vicinity of the screw area to assist removal

- The Cam/Shaft assembly (2 & 4 / 2, 4 & 6) can now be lifted from the Body (1). Remove and discard the Shaft O-Rings (24 / 23 & 24) and Bush (11).
- Loosen and remove Screws (17) from both ends of the Body (1). Slide Cam Guide (8) from Buttons (19) and out of Body (1). Remove and discard Guide Bushes (14) in Buttons (19).

#### 8.4.1.4 – Spring Cylinder Disassembly

Refer to J100454

**WARNING: BEFORE COMMENCING ANY DISASSEMBLY OF THE SPRING CYLINDER IT MUST BE REMOVED FROM THE ACTUATOR BODY BY FOLLOWING THE INSTRUCTIONS ABOVE.**

- Remove Cover Plate (3) and discard O-ring (8)

**IMPORTANT NOTICE:** The Camtorc Actuator contains a pre-loaded spring assembly. Do not, under any circumstances, attempt to maintain or service this item before reading the following instruction carefully.

- The Spring Cylinder Assembly is held together using Socket Head Capscrews (12) retaining the Intermediate Cap (2) to the Spring Cylinder (1).
- Loosen and remove **ONE** Socket Head Capscrew (12) and replace with suitable studding (see Table below) through the Intermediate cap (2) and out through the reverse side of the Spring Cylinder Flange.



- Place a washer and full nut onto the studding to secure the Intermediate Cap (2) to the Spring Cylinder flange and TIGHTEN.
- Repeat for remaining quantity of Socket Head Capscrews/Studding ensuring that the studding is evenly dispersed around the face of the Intermediate Cap (2).

**IMPORTANT DO NOT REMOVE OR REPLACE MORE THAN ONE CAP SCREW AT A TIME**





The following table shows the requirement of studding for dismantling the spring return units:-

<b>Size of Actuator</b>	<b>Cylinder Size</b>	<b>Type</b>	<b>Qty.</b>	<b>Length (mm)</b>	<b>Compressed Spring Force (Kg)</b>
30SR	1	M8	4	300	390
	2	M8	4	320	400
	3	M12	4	450	660
40SR	1	M10	4	730	950
	2	M12	6	800	1400
50SR	1	M12	6	800	1400
	2	M12	8	1000	1900
70SR	1	M12	8	1000	1900
	2	M12	8	1000	2400
85SR	1	M12	8	1000	3300
	2	M20	8	1000	4200
100SR	1	M20	8	1000	4200
	2	M20	12	1000	5000
150SR	1	M20	12	1250	5600
	2	M20	12	1250	9150

- Once all stud bars and full nuts are in place, evenly release the full nuts until the Spring is fully released, then remove all full nuts and lift off the Intermediate Cap (2) and Spring Piston/Stem (4 / 5). Slide stem (5) out of Intermediate Cap (2)
- Remove and Discard the Spring Piston O-Ring (10) and Slip Strip (11) (if fitted), the Stem O-Ring (9) in the Intermediate Cap (2) (if fitted), and the Spring Cylinder O-Ring (7).

Note: If the bush in the Intermediate Cap (2) needs replacing, the Cap will have to be returned to MATIC for refurbishing.



- Thoroughly clean and inspect all components for evidence of wear or damage. Where necessary obtain spare components from Camtorc before re-assembly.

#### 8.4.2 - Reassembly

**WARNING: DO NOT ALLOW SOLVENTS TO COME INTO CONTACT WITH ANY ELASTOMERIC SEALS, PTFE BEARINGS, OR WEAR PADS.**

##### 8.4.2.1 - General Notes

If not already performed, ensure all seals, and bushes are removed from the Actuator components, taking care not to damage their individual sealing surfaces.

Before commencing the reassembly of the Actuator, all components must be inspected and cleaned. Particular attention must be paid to sealing surfaces and screw threads.

To ease reassembly, lubricate all seals using a light mineral oil.

##### 8.4.2.2 - Body Reassembly

Refer to J100444 and CS150-BODY-IOM

Where 2 Item numbers are quoted for reference on a part in the drawings, the first number relates to J100444 and the second relates to CS150-BODY-IOM.

- Fit Guide Bushes (14) and Wear Pads (7) into Buttons (19). Slide Cam Guide (8) through end of Body (1) and through the each Guide Bush(14) in the Buttons (19) in turn, taking care that the Wear Pads (8) face one another. Continue to slide the Cam Guide (8) through to the other side of the Body (1). Secure the Cam Guide (8) with the Screws (17).
- Fit Bush (11) into Body (1). Fit Shaft O-Rings (24 / 23 & 24) onto Shaft (4 / 4 & 6). Fit Cam/Shaft assembly (2 & 4 / 2,4 & 6) into Body (1).
- Position the Cam Spacers (9), 2-off below the Cam (2) and 2-off above. Offer up the Buttons (19) to the Spacers (9) and secure assembly in place by connecting the Connection Plates (28) to the Spacers (9) using Screws / Nuts (15).

These Screws are retained using Loctite™ 601

- Refit Top Bush (12) into Top Plate (10). Refit Top Plate Gasket (22) and fit Top Plate (10) onto Cover (3) using Top Plate Screws (31 / 27).



- Replace Cover Gasket (21) and secure Cover (3) onto Body (1) with Cover Screws (5).

NOTE: The steps below only relate to models Cx30 to Cx100

- Install Stop Screw (16) into thread in Body (1).
- Install Dowty Washers (23) to Stop Screw (16) located in the face of the Body (1).
- Install Locknuts (26) to Stop Screw (16)

**WARNING: Ensure that the measurement of the Stop Screw recorded previously is accurately reset before tightening the Locknut (26). This will ensure that the Actuator's original Open/Close position is maintained.**

- Install the End Stop Nuts (30) to two in number Stop Screw (16).

#### 8.4.2.3 – Spring Cylinder Reassembly

Refer to J100454

- Fit Stem O-Ring (9) (if fitted in the Intermediate Cap centre hole), Spring Piston O-Ring (10) and Slip Strip (11) (if fitted) and the Spring Cylinder O-Ring (7).
- Slide Stem (5) into Intermediate Cap (2). The Piston (4) should be on the opposite side of the Intermediate Cap (2) from the Countersunk Holes.
- Fit the Spring Nest (6) into the Spring Cylinder (1)
- Locate Sub Assembly of the Intermediate Cap (2), Spring Piston (4) and Stem (5) onto the top of the Spring Nest (6) within the Spring Cylinder (1).
- Install suitable studding through the Intermediate Cap (2) and out through the reverse side of the Spring Cylinder Flange. Place washer and full nut onto the studding to secure to the Intermediate Cap (2) to the Cylinder and **TIGHTEN**.
- Once all stud bars and full nuts are in place, evenly tighten the full nuts until the Intermediate Cap (2) is flush against the Spring Cylinder (1) Flange. Remove studding and replace with Socket Head Capscrew (12).

**IMPORTANT: DO NOT REMOVE OR REPLACE MORE THAN ONE STUD BAR WITH SOCKET HEAD CAP SCREW AT A TIME**

- Fit O Ring (8) into recess on Intermediate Cap (2).



- Fit Cover Plate (3)

#### 8.4.2.4 - Cylinder Reassembly

Refer to J100455

- Fit O-Ring (7) into recess in Intermediate Cap (1)
- Fit O-Ring (11) onto Intermediate Cap (1)
- Carefully slide Cylinder (3) over O-Ring (11) onto Intermediate Cap (1)
- Fit Slip Strip (9), O-Ring (10) and Back Up Ring (12) to Hydraulic Piston (8).
- Carefully slide the Hydraulic Piston (8) into the Cylinder (3) taking care to orientate correctly.
- Fit O-Ring (10) and Back Up Ring (12) to End Cap (2)
- Fit End Cap (2) onto Cylinder (3), taking care not to damage the O-Rings on the End Cap. The End Cap will need to be aligned over the Tie Rods (4)/
- Secure the End Cap (2) with the Hex Nuts (6)

#### 8.4.2.5 – Cylinder Re-Assembly to Body

**NOTE: Ensure the cylinders are re-assembled on the same side of the Body (1) as they were prior to Disassembly. Always fit the Hydraulic Cylinder before the Spring Cylinder on Spring Return units.**

Refer to J100444 and CS150-BODY-IOM

- Align and position Cylinder onto Actuator Body, with the Cylinder Stem passing through the central hole and ensuring the Cylinder Gasket (20) is in place. Loosely secure the Cylinder using the 4 x Screw (18).
- If removed during disassembly, fit Connection Plate (28) to Cylinder Stem, securing with Screw (17).
- Secure Connection Plate (28) to Button (19) and secure with 4 x Screw /Nut (15).
- Fit Body Cover (3) and secure with Screws (6).



## **9 - SUBMERSIBLE ACTUATORS**

### **REFERENCE DOCUMENTS**

Drawing J100347-SUB – S-Type Submersible Actuator – Hook Up Drawing

The Type S Submersible Actuator can be considered the same as a standard Type S with a few key exceptions. Therefore the standard actuator IOM document applies in most aspects.

The key special considerations are:

#### **9.1 - INSTALLATION**

When installing a Type S actuator in a submersed environment it is CRITICAL to ensure that all supply and return ports are piped from and to the non-submersed environment using appropriate and correctly installed fittings and piping PRIOR to submersing the actuator. This may require removing any factory fitted breathers/silencers fitted to breather ports. Failure to do so may result in water ingress to the actuator and negation of warranty.

Type S actuators are constructed from Carbon Steel. Special care should be taken on installation to ensure no damage occurs to the paint finish of the actuator on installation as any exposure of the base metal to the submersed environment may accelerate actuator corrosion.

#### **9.2 - MAINTENANCE**

When undertaking maintenance of a submersed actuator, the unit should be transferred to the non-submersed environment prior to any disconnection of supply or return ports.

Repair/maintenance of the Actuator coating should be done in accordance with factory recommendations (consult factory). However, due to the nature of the submersible actuator, it is recommended that the unit be returned to Imtex Controls for any disassembly work to be undertaken.

## 10 – ATEX & UKCA INFORMATION

### 10.1 – REFERENCED STANDARDS

The following standards have been referred to in these instructions and are applicable to the use of this product when used in an environment where an explosive atmosphere may be present:

#### ATEX

EN 13463-1:2009

EN 13463-2003





#### UKCA

EN ISO 80079-36:2016

EN ISO 8079-37:2016

### 10.2 – PRODUCT LABELLING

The label on the monitor should be as below:

		CAMTORC ACTUATORS Deeside, Flintshire - UK www.camtorc.com Tel +44(0)8700-340002	
ACTUATOR:	<input type="text"/>	FAIL:	<input type="text"/>
SERIAL:	<input type="text"/>	Yr:	<input type="text"/>
TORQUE(Nm):	BtO <input type="text"/> EtC <input type="text"/>	@	<input type="text"/> Barg
THRUST(N):			
AMB TEMP RANGE °C	Min: <input type="text"/>	Max: <input type="text"/>	
PRESSURE (Barg)	Min: <input type="text"/>	Max: <input type="text"/>	
ASSEMBLY:	<input type="text"/>		
TAG NO:	<input type="text"/>		
 SIRA 09ATEX6335X	 CSAE 21UKEX6577X	 II 2 G IIC T Gb	 II 2 G Ex h IIC T Gb
WARNING: DO NOT OPEN WHEN ENERGISED			

NOTE: The year of manufacture of the monitor can be obtained from the last 2 digits of the serial number.



## APPENDIX

### DRAWINGS & PARTS LISTS REFERENCED IN MAIN DOCUMENT

The following drawings are referenced throughout this document and are available in this section.

Type S – Body – Generic Parts	J100457-HYD
Type S – Spring Cylinder – Generic Parts	J100458
Generic Hydraulic MHS Assembly	J100459
Generic Hydraulic M Assembly	J100460
Type S (and Type A) Actuator – Operation	J100462
Type C – Body – General Parts Assembly (Sizes 30 to 100)	J100444
Cx150 Body Assembly – Parts Detail	CS150-BODY-IOM
Type C – Hydraulic Cylinder – General Parts Assembly	J100455
Type C – Spring Cylinder – General Assembly	J100454
Type C – Hydraulic Actuator – Principle of Operation	J100463
S-Type Submersible Actuator – Hook Up Drawing	J100347-SUB

ITEM	Part Description	Type S Material	Type SX Material	QTY.
1	Body	Carbon Steel	316SS	1
2	Shaft	Stainless Steel	Stainless Steel	1
3	Piston Spacer	Carbon Steel	316SS	2
4	Connecting Piston	Carbon Steel	316SS	1
5	Piston 2 (Non-Pressure in SR)	Carbon Steel	316SS	1
6	Cam	Carbon Steel	316SS	1
7	Wear Pad	VX1 PTFE	VX1 PTFE	2
8	DU Bush	Bronze / PTFE	Bronze / PTFE	2
9	Key	Key Steel	Key Steel	1
10	Set Screw	High Tensile Carbon Steel	A4	1
11	CSK Screw	High Tensile Carbon Steel	A4	4
12	O-Ring	Nitrile / EPDM / Viton	Nitrile / EPDM / Viton	2
13	O-Ring	Nitrile / EPDM / Viton	Nitrile / EPDM / Viton	2
14	O-Ring	Nitrile / EPDM / Viton	Nitrile / EPDM / Viton	1
15	Slip Strip	PTFE	PTFE	1
16	Hydraulic Ram	Carbon Steel	316SS	1
17	CSK Screw	High Tensile Carbon Steel	A4	1
18	O-Ring	Nitrile /EPDM /Viton	Nitrile /EPDM /Viton	1

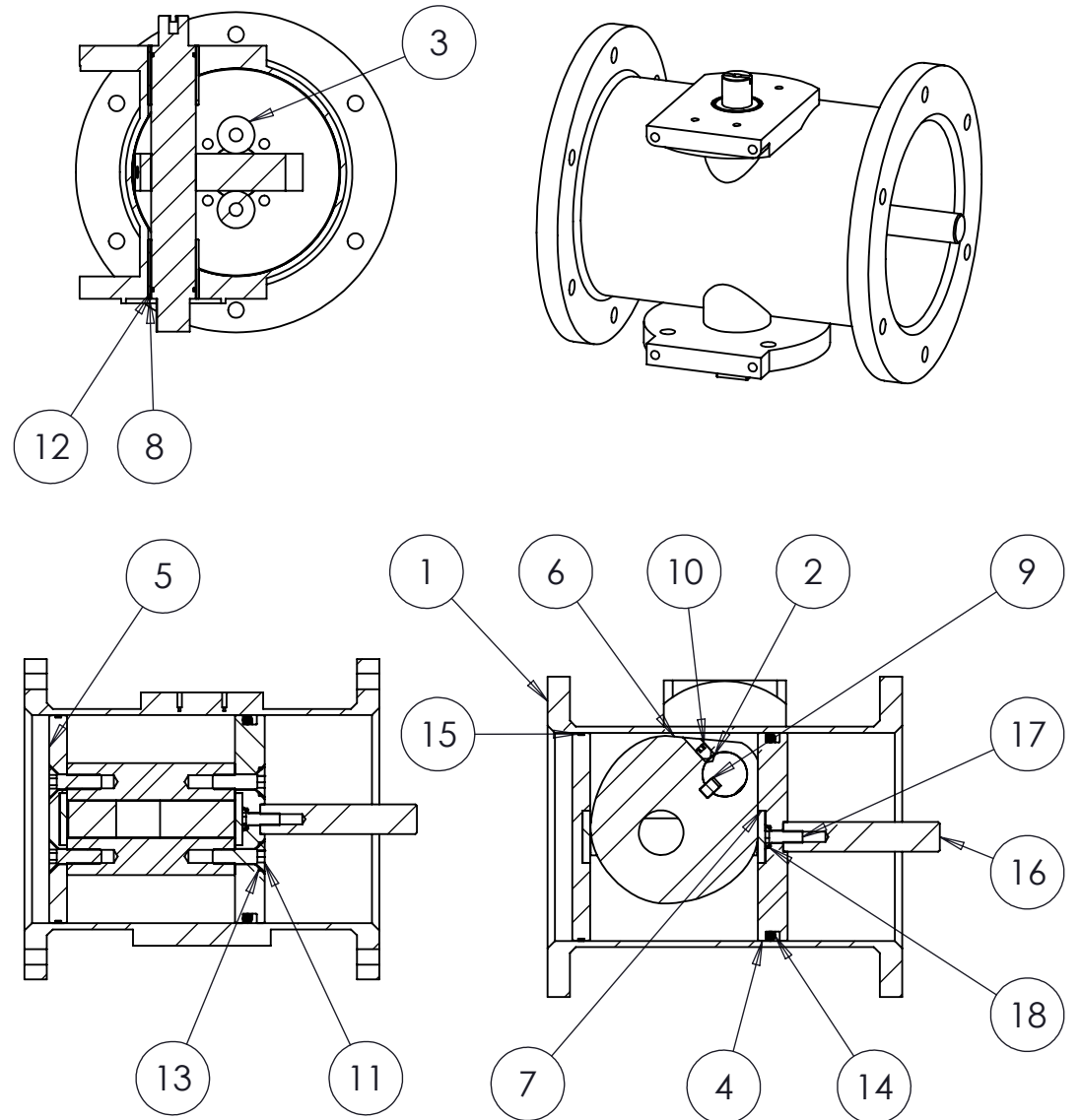

REV	DRAWN	DATE	CHK'D	ECO
	PT	19.2.15		15-2341

UNLESS OTHERWISE SPECIFIED:  
DIMENSIONS ARE IN MILLIMETERS  
SURFACE FINISH: 3.2  
TOLERANCES:  
LINEAR: ±0.25mm  
ANGULAR: ±0.5°

TITLE:  
Type S - Body - Generic Parts  
- Hydraulic

This private & confidential drawing is the property of Camtorc Actuators, UK and cannot be copied or reproduced without the express written permission of the Company.

**Camtorc Actuators**  
United Kingdom. Tel:+44(0)870-0340002  
Website: [www.camtorc.com](http://www.camtorc.com)

DEBUR AND  
BREAK SHARP  
EDGES  
MATERIAL:  
WEIGHT: - Excl Valve

DWG NO.  
J100457-HYD

SCALE:1:5

SHEET 1 OF 1

ACTIVE  
-  
STATUS  
R  
A4



ITEM NO.	Part Description	Type S Material	Type SX Material	Default/QTY.
1	Spring Cylinder	Carbon Steel	316SS	1
2	Button	Carbon Steel	316SS	1
3	Intermediate Cap	Carbon Steel	316SS	1
4	Spring Piston	Carbon Steel	316SS	1
5	Stop Adjuster	Carbon Steel	316SS	1
6	Stem	Carbon Steel	316SS	1
7	End Stop Nut	Carbon Steel	316SS	1
8	O-Ring	Nitrile / EPDM / Viton	Nitrile / EPDM / Viton	1
9	O-Ring	Nitrile / EPDM / Viton	Nitrile / EPDM / Viton	1
10	O-Ring	Nitrile / EPDM / Viton	Nitrile / EPDM / Viton	1
11	O-Ring	Nitrile / EPDM / Viton	Nitrile / EPDM / Viton	1
12	Hex Head Screw	High Tensile Carbon Steel	A4	6
13	Skt Hd Screw	High Tensile Carbon Steel	A4	4
14	CSK Screw	High Tensile Carbon Steel	A4	1
15	Hex Nut	High Tensile Carbon Steel	A4	1
16	Dowty Washer	Carbon Steel/Nitrile	Stainless Steel/Nitrile	2
17	Hex Bolt	High Tensile Carbon Steel	A4	1
18	Dowty Washer	Carbon Steel/Nitrile	Stainless Steel/Nitrile	1
19	Slip Strip	PTFE	PTFE	1
20	Spring Nest	Spring Steel	Spring Steel	1

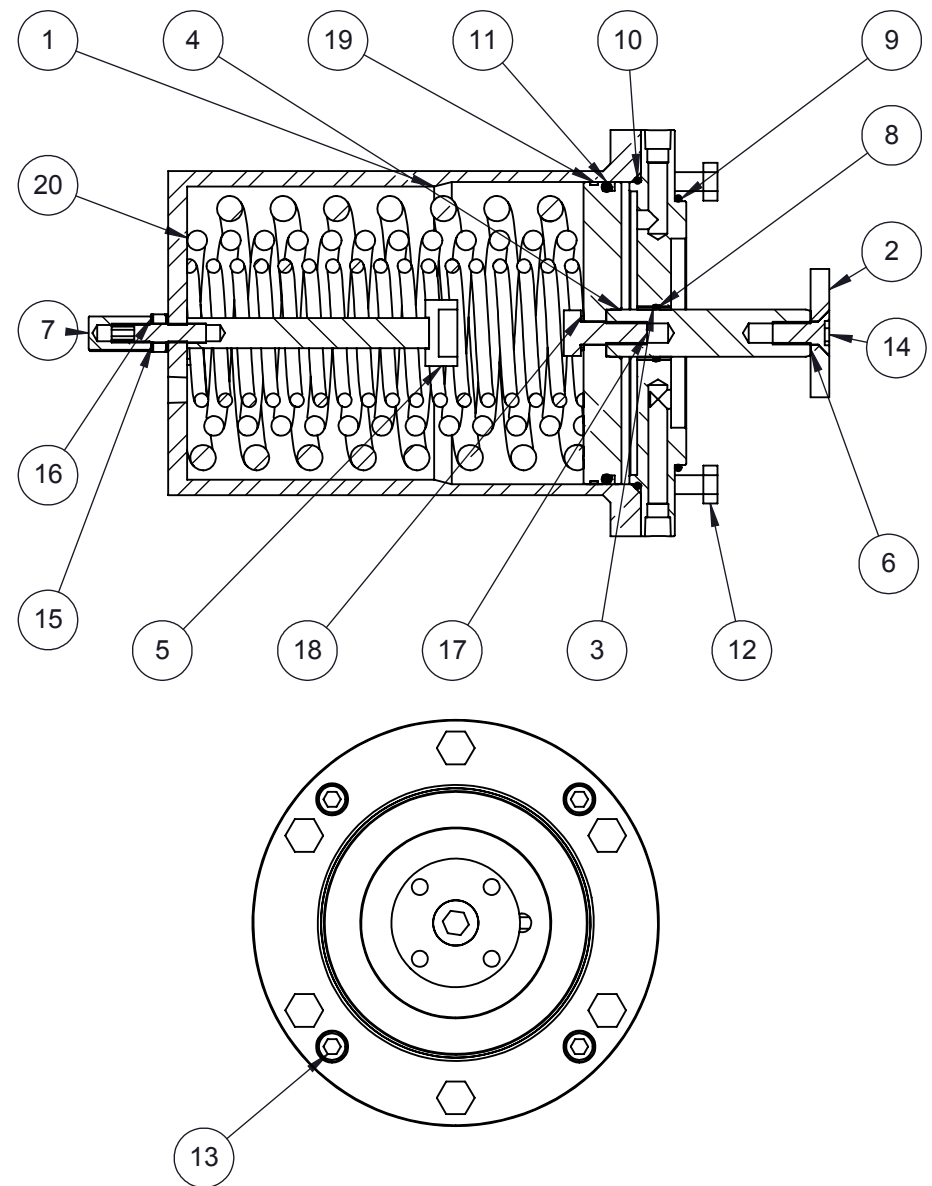

REV	DRAWN	DATE	CHK'D	ECO
	PT	20.12.13		13-2172

UNLESS OTHERWISE SPECIFIED:  
DIMENSIONS ARE IN MILLIMETERS  
SURFACE FINISH: 3.2  
TOLERANCES:  
LINEAR: ±0.25mm  
ANGULAR: ±0.5°

TITLE:  
**Type S - Spring Cylinder -  
Generic Parts**

This private & confidential drawing is the property of Camtorc Actuators, UK and cannot be copied or reproduced without the express written permission of the Company.

**Camtorc Actuators**  
United Kingdom. Tel:+44(0)870-0340002  
Website: [www.camtorc.com](http://www.camtorc.com)

DEBUR AND  
BREAK SHARP  
EDGES  
MATERIAL:  
WEIGHT: - Excl Valve

DWG NO. **J100458**  
SCALE:1:5  
SHEET 1 OF 1

ACTIVE  
-  
STATUS  
R  
**A4**

ITEM NO.	Part Description	Type S -Material	Type SX -Material	QTY.
1	Hydraulic Cylinder Assembly	Carbon Steel	316SS	1
2	Hydraulic Piston	Carbon Steel	316SS	1
3	O-Ring	Nitrile	Nitrile	1
4	Slip Strip	PTFE	PTFE	1
5	GACO Seal	NBR Polymer	NBR Polymer	1
6	O-Ring	Nitrile	Nitrile	1
7	Hex Bolt	High Tensile Carbon Steel	A4	6
8	Hex Nut	High Tensile Carbon Steel	A4	6
9	End Stop Nut	Carbon Steel	316SS	1
10	Hex Nut	High Tensile Carbon Steel	A4	1
11	Dowty Washer	Carbon Steel/Nitrile	StSt / Nitrile	2
12	Endstop Screw	High Tensile Carbon Steel	A4	1
13	Hydraulic Back Up Flange	Carbon Steel	316SS	1
14	GACO Seal	NBR Polymer	NBR Polymer	1
15	O-Ring	Nitrile	Nitrile	1
16	O-Ring	Nitrile	Nitrile	1

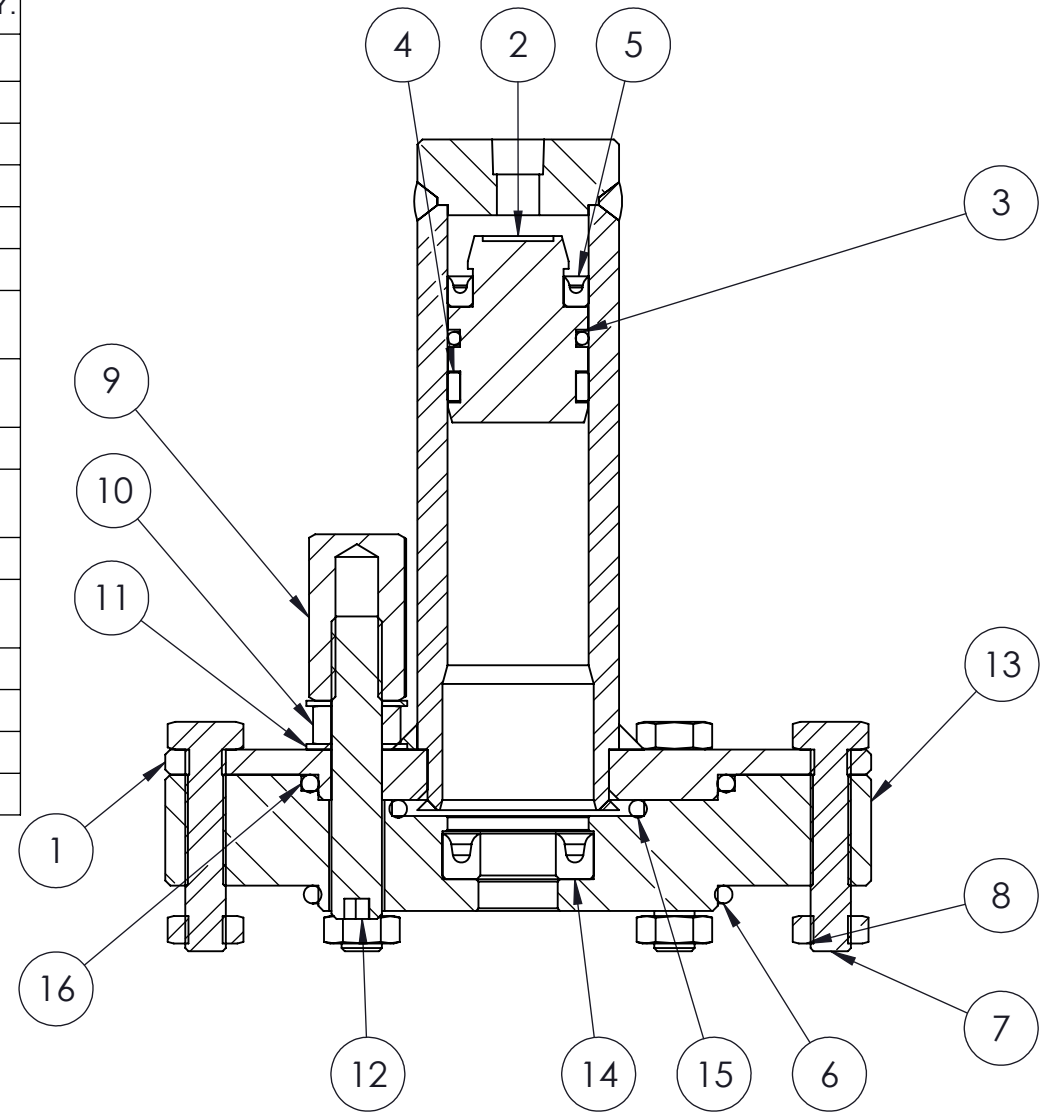

## SECTION

REV	DRAWN	DATE	CHK'D	ECO
	PT	4/2/2016		16-2472

UNLESS OTHERWISE SPECIFIED:  
DIMENSIONS ARE IN MILLIMETERS  
SURFACE FINISH: 3.2  
TOLERANCES:  
LINEAR:  $\pm 0.25\text{mm}$   
ANGULAR:  $\pm 0.5^\circ$

TITLE:

Generic Hydraulic MHS  
Assembly

This private & confidential drawing is the property of Camtorc Actuators, UK and cannot be copied or reproduced without the express written permission of the Company.

**Camtorc Actuators**  
United Kingdom. Tel:+44(0)870-0340002  
Website: [www.camtorc.com](http://www.camtorc.com)

DEBUR AND  
BREAK SHARP  
EDGES

MATERIAL:

WEIGHT: - Excl Valve

DWG NO.

J100459

SCALE:1:5

SHEET 1 OF 1

ACTIVE  
A  
STATUS

A4

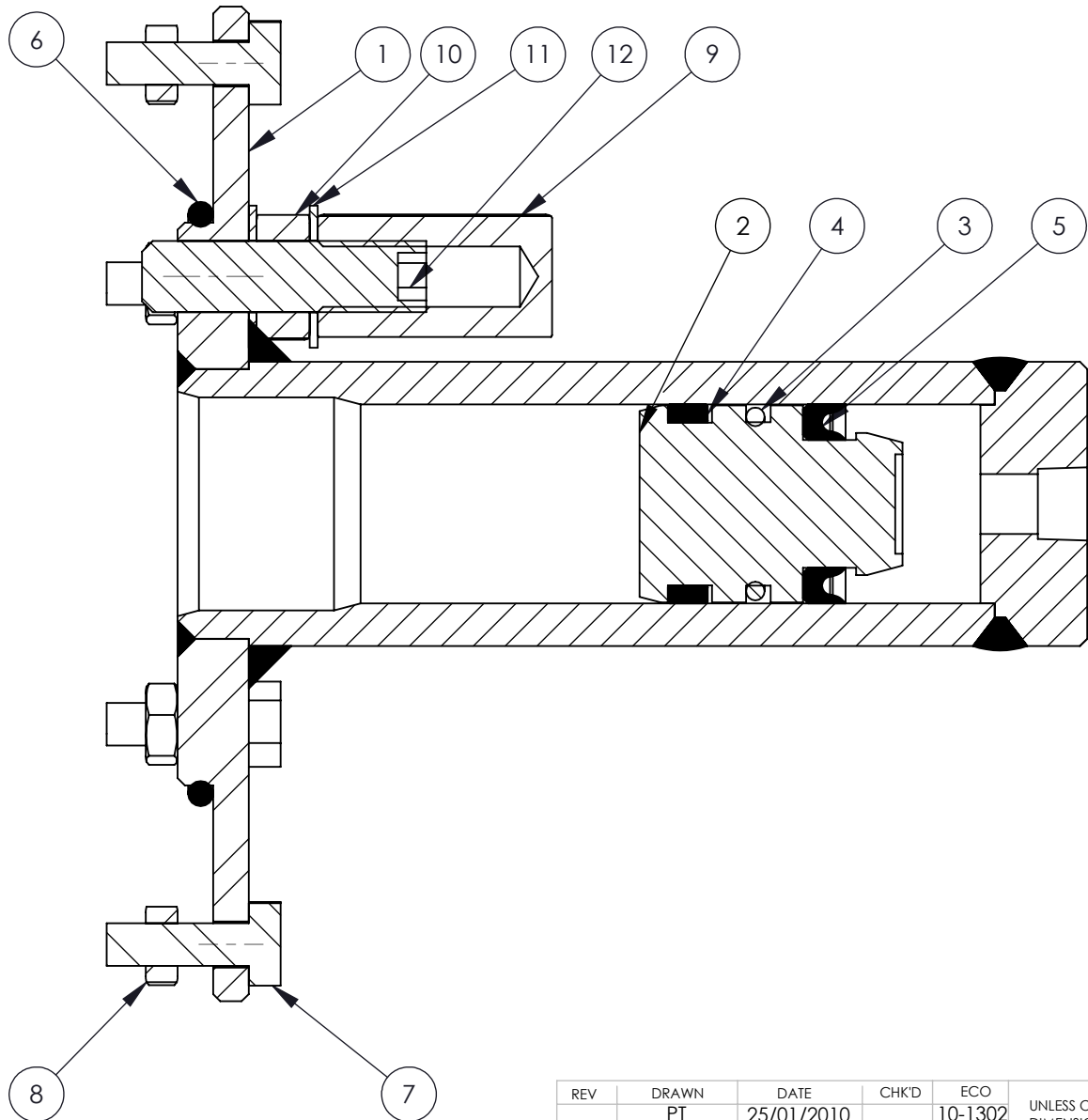

ITEM NO.	Part Description	Type S - Material	Type SX - Material	QTY.
1	Hydraulic Cylinder Assembly	Carbon Steel	316SS	1
2	Hydraulic Piston	Carbon Steel	316SS	1
3	O-Ring	Nitrile	Nitrile	1
4	Slip Strip	PTFE	PTFE	1
5	GACO Seal	NBR Polymer	NBR Polymer	1
6	O-Ring	Nitrile	Nitrile	1
7	Hex Bolt	High Tensile Carbon Steel	A4	6
8	Hex Nut	High Tensile Carbon Steel	A4	6
9	Blind Nut	Carbon Steel	316SS	1
10	Hex Nut	High Tensile Carbon Steel	A4	1
11	Dowty Washer	Carbon Steel/Nitrile	StSt / Nitrile	2
12	Stop Screw	High Tensile Carbon Steel	A4	1

REV	DRAWN	DATE	CHK'D	ECO
	PT	25/01/2010		10-1302

UNLESS OTHERWISE SPECIFIED:  
 DIMENSIONS ARE IN MILLIMETERS  
 SURFACE FINISH: 3.2  
 TOLERANCES:  
 LINEAR: ±0.25mm  
 ANGULAR: ±0.5°

TITLE:  
**Generic Hydraulic M Assembly**

This private & confidential drawing is the property of Camtorc Actuators, UK and cannot be copied or reproduced without the express written permission of the Company.

**Camtorc Actuators**  
 United Kingdom. Tel:+44(0)870-0340002  
 Website: [www.camtorc.com](http://www.camtorc.com)

DEBUR AND BREAK SHARP EDGES  
 MATERIAL: As Stated  
 WEIGHT: 1.64 - Excl Valve

DWG NO. **J100460**  
 SCALE:1:1  
 SHEET 1 OF 1  
 ACTIVE STATUS  
 A4

### SPRING RETURN UNIT (M TYPE CYLINDER)

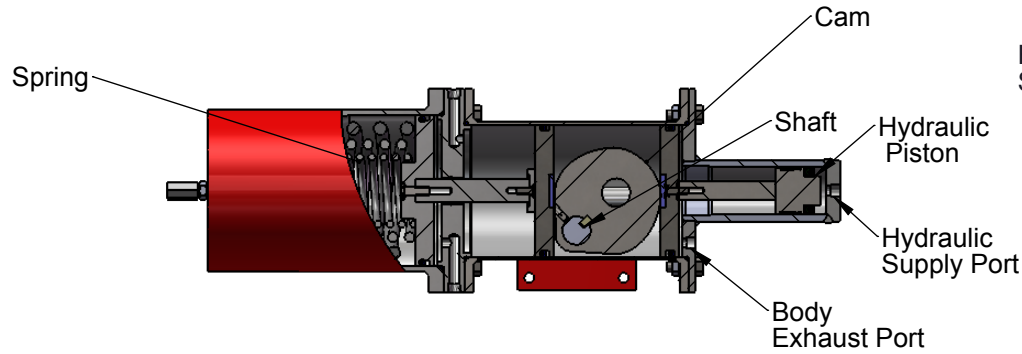

### DOUBLE ACTING UNIT (M TYPE CYLINDER)

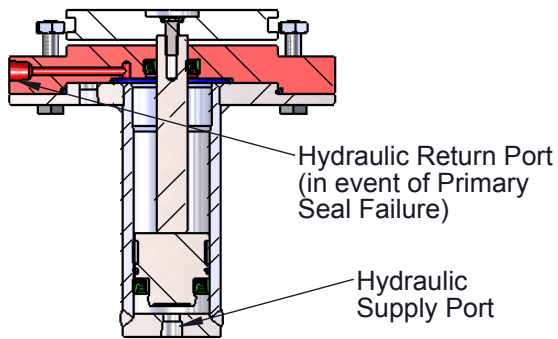
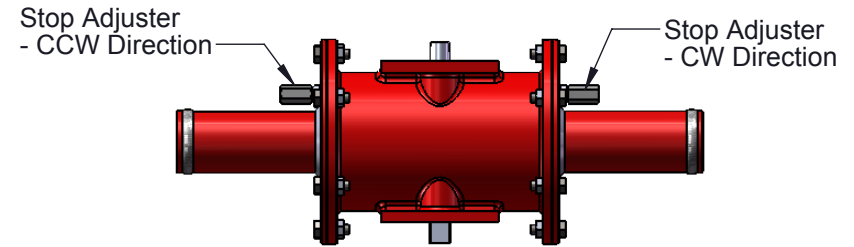
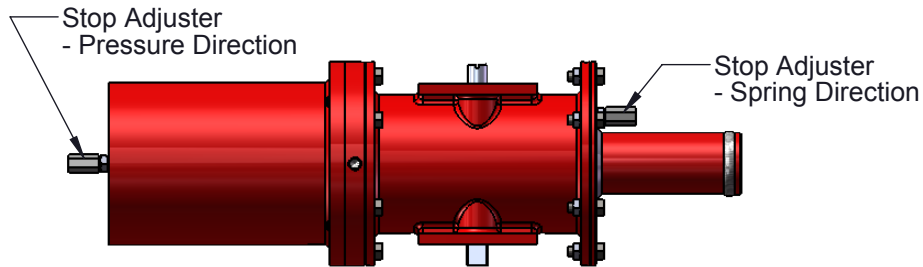
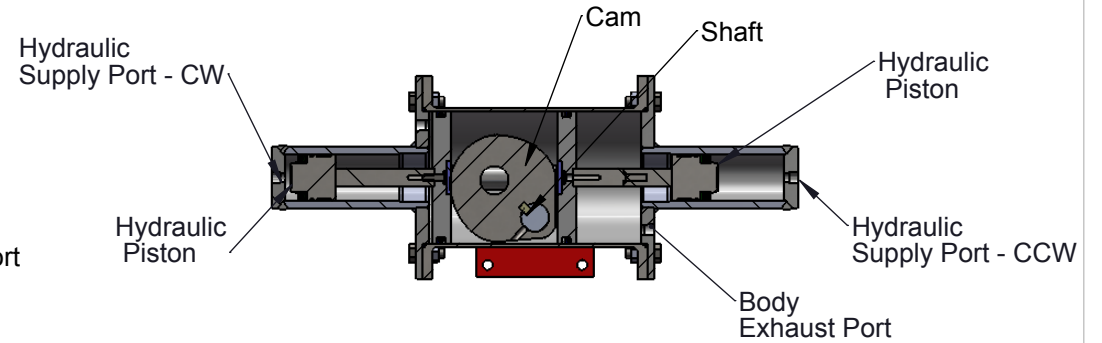

### MHS TYPE CYLINDER VARIANT

REV	DRAWN	DATE	CHK'D	ECO
	PT	7.10.09		09-1158

UNLESS OTHERWISE SPECIFIED:  
 DIMENSIONS ARE IN MILLIMETERS  
 SURFACE FINISH: 3.2  
 TOLERANCES:  
 LINEAR: ±0.25mm  
 ANGULAR: ±0.5°

TITLE:  
**Type S (and Type A) Actuator Operation**

This private & confidential drawing is the property of Camtorc Actuators, UK and cannot be copied or reproduced without the express written permission of the Company.

**Camtorc Actuators**  
 United Kingdom. Tel:+44(0)870-0340002  
 Website: [www.camtorc.com](http://www.camtorc.com)

DEBUR AND BREAK SHARP EDGES  
 MATERIAL:  
 WEIGHT: - Excl Valve

DWG NO. **J100462**

SCALE:1:10

SHEET 1 OF 1

ACTIVE  
 STATUS R  
**A4**

ITEM NO.	DESCRIPTION	CS Version Material	CX Version Material	QTY.
1	Body	CS	StSt	1
2	Cam	CS	StSt	1
3	Cover Plate	CS	StSt	1
4	Shaft	316SS or 17-4PH	316SS or 17-4PH	1
5	Drive Button	CS	StSt	2
6	Skt Hd Screw	High Tensile Carbon Steel	A4	10
7	Flat Washer	Carbon Steel	A4	10
8	Wear Pad	UHMWPE	UHMWPE	2
9	Cam Guide	CS	StSt	1
10	Cam Spacer	CS	StSt	4
11	Top Plate	CS	StSt	1
12	Glacier Bush	Steel/PTFE	Bronze/PTFE	1
13	Glacier Bush	Steel/PTFE	Bronze/PTFE	1
14	Dowel Pin	High Tensile Steel	316SS	2
15	Glacier Bush	Steel/PTFE	Bronze/PTFE	2
16	CSK Screw	High Tensile Carbon Steel	A4	8
17	Set Screw	High Tensile Carbon Steel	A4	2
18	CSK Screw	High Tensile Carbon Steel	A4	3
19	Cap Screw	High Tensile Carbon Steel	A4	8
20	CSK Screw	High Tensile Carbon Steel	A4	1
21	Cylinder Gasket	Klingersil	Klingersil	2
22	Cover Gasket	Klingersil	Klingersil	1
23	Top Plate Gasket	Klingersil	Klingersil	1
24	Dowty Washer	CS / Nitrile	StSt / Nitrile	4
25	Nut	High Tensile Carbon Steel	A4	2
26	Parallel Key	Key Steel	Key Steel	1
27	Set Screw	High Tensile Carbon Steel	A4	1
28	Connection Plate	CS	StSt	2
29	End Stop Nut	CS	StSt	2
30	O-Ring	Nitrile / EPDM / Viton	EPDM / Viton	2
31	Cap Screw	High Tensile Carbon Steel	A4	2

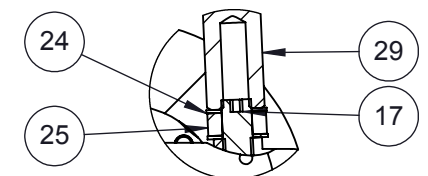

DETAIL H - Broken Out Section

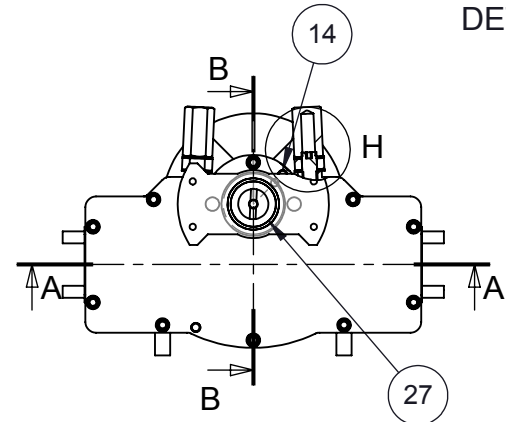

SECTION B-B

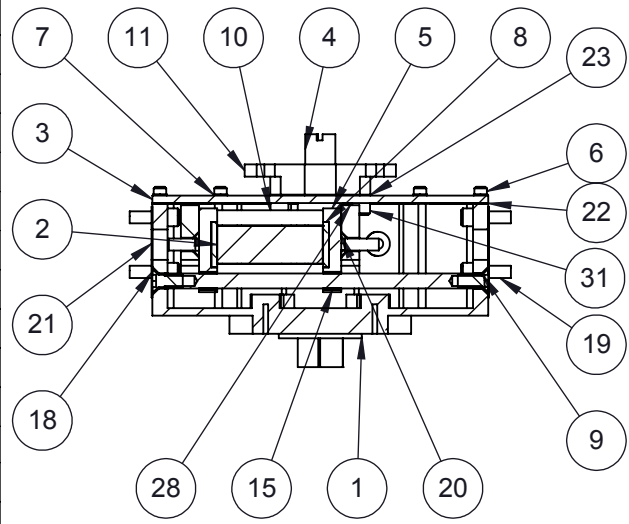

SECTION A-A

NOTE:

'CS' - Carbon Steel to EN10277 - 1.0718 or Equivalent  
'StSt' - 316 Grade Stainless Steel or Equivalent

REV	DRAWN	DATE	CHK'D	ECO
	PT	23.5.13		13-2076
A		26.11.14		14-2076A

UNLESS OTHERWISE SPECIFIED:  
DIMENSIONS ARE IN MILLIMETERS  
SURFACE FINISH: 3.2  
TOLERANCES:  
LINEAR: ±0.25mm  
ANGULAR: ±0.5°

TITLE:  
**Type C - Body - General Parts  
Assembly (sizes 30 to 100)**

This private & confidential drawing is the property of Camtorc Actuators, UK and cannot be copied or reproduced without the express written permission of the Company.

**Camtorc Actuators**  
United Kingdom. Tel:+44(0)870-0340002  
Website: [www.camtorc.com](http://www.camtorc.com)

DEBUR AND  
BREAK SHARP  
EDGES  
MATERIAL:  
WEIGHT: - Excl Valve

DWG NO. **J100444**  
SCALE:1:5  
SHEET 1 OF 1

ACTIVE  
A  
STATUS  
R  
A4

ITEM NO.	Part Description	CS Version Material	CX Version Material	QTY.
1	Body	Carbon Steel	Stainless Steel	1
2	Cam	EN8	17-4PH	1
3	Cover Plate	Carbon Steel	Stainless Steel	1
4	Shaft	17-4PH	17-4PH	1
5	Socket Set Screw	High Tensile Carbon Steel	A4	20
6	Top Shaft	17-4PH	17-4PH	1
7	Wear Pad	UHMWPE	UHMWPE	2
8	Cam Guide	Carbon Steel	Stainless Steel	1
9	Cam Spacer	Carbon Steel	Stainless Steel	4
10	Top Plate	Carbon Steel	Stainless Steel	1
11	Glacier Bush	Steel/PTFE	Bronze/PTFE	1
12	Glacier Bush	Steel/PTFE	Bronze/PTFE	1
13	Dowel Pin	Hardened Steel	316SS	6
14	Glacier Bush	Steel/PTFE	Bronze/PTFE	2
15	Nut	Carbon Steel	Stainless Steel	8
16	Dowel Pin	Hardened Steel	316SS	6
17	Socket Set Screw	High Tensile Carbon Steel	A4	1
18	Hex Head Bolt	Carbon Steel	Stainless Steel	8
19	Drive Button	Carbon Steel	Stainless Steel	2
20	Cylinder Gasket	Klingsil	Klingsil	2
21	Cover Gasket	Klingsil	Klingsil	1
22	Top Plate Gasket	Klingsil	Klingsil	1
23	O-Ring	Nitrile / EPDM / Viton	Nitrile / EPDM / Viton	1
24	O-Ring	Nitrile / EPDM / Viton	Nitrile / EPDM / Viton	1
25	Parallel Key	Key Steel	Key Steel	2
26	Socket Cap Screw	High Tensile Carbon Steel	A4	4
27	Socket Head Screw	High Tensile Carbon Steel	A4	4
28	Connection Plate	Carbon Steel	Stainless Steel	2

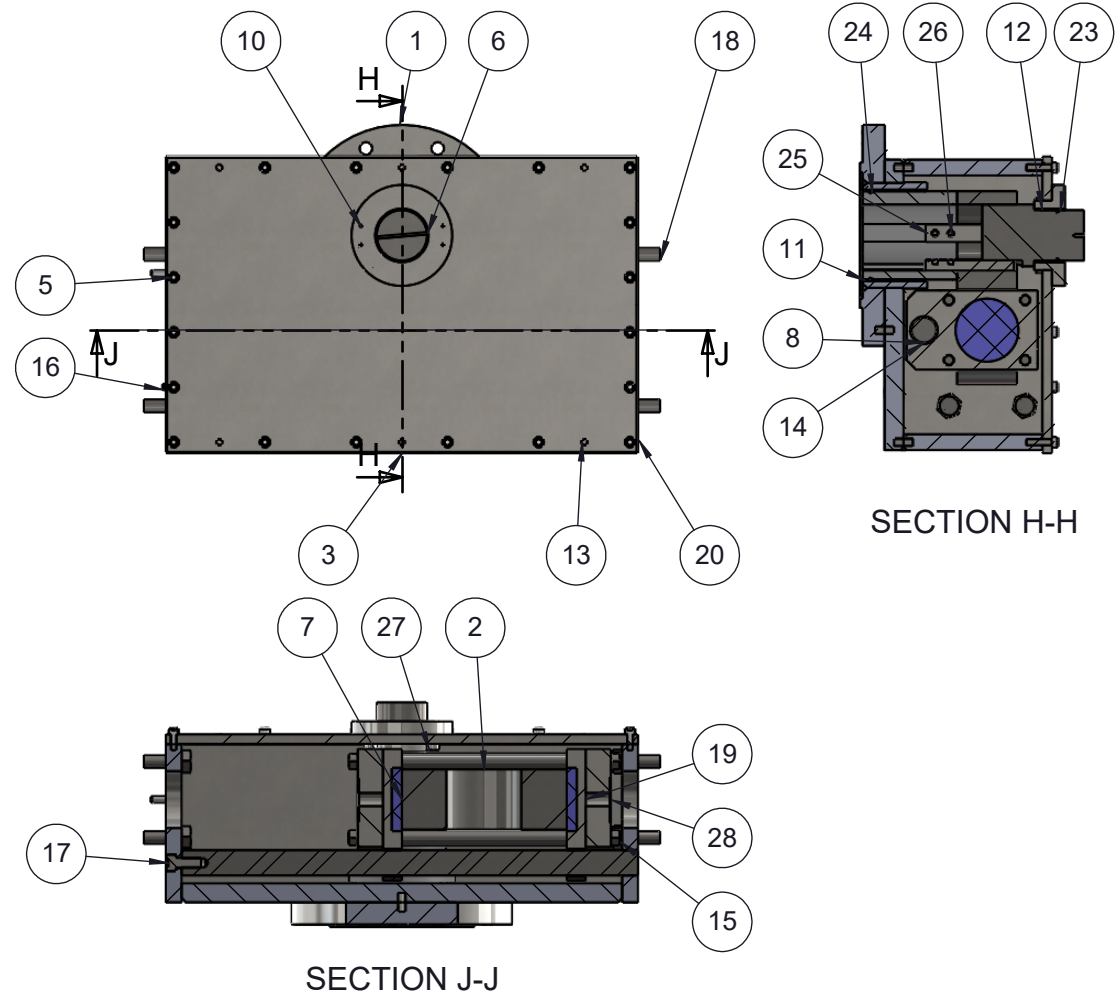

SEAL KIT - SK - Items 20, 21, 22, 23, 24

REPAIR KIT - RK - Items 20, 21, 22, 23, 24, 7, 11, 12, 14

**NOTE:**

'Carbon Steel' - to EN10277 - 1.0718 or Equivalent  
 'Stainless Steel' - 316 Grade Stainless Steel or Equivalent

REV	DRAWN	DATE	CHK'D	ECO
	PT	18.5.17		17-2624

UNLESS OTHERWISE SPECIFIED:  
 DIMENSIONS ARE IN MILLIMETERS  
 SURFACE FINISH: 3.2  
 TOLERANCES:  
 LINEAR: ±0.25mm  
 ANGULAR: ±0.5°

TITLE:  
**Cx150 Body Assembly - Parts Detail**

This private & confidential drawing is the property of Camtorc Actuators, UK and cannot be copied or reproduced without the express written permission of the Company.

**Camtorc Actuators**  
 United Kingdom. Tel:+44(0)870-0340002  
 Website: [www.camtorc.com](http://www.camtorc.com)

DEBUR AND BREAK SHARP EDGES  
 MATERIAL:  
 WEIGHT: - Excl Valve

DWG NO. **CS150-BODY-IOM**

SCALE:1:12

SHEET 1 OF 1

ACTIVE - STATUS R  
**A4**

ITEM NO.	Part Description	CS Version Material	CX Version Material	QTY
1	Hydraulic Intermediate Cap	Carbon Steel	316SS	1
2	Hydraulic End Cap	Carbon Steel	316SS	1
3	Hydraulic Cylinder	Carbon Steel	316SS	1
4	Tie Rod	EN8 Steel	316SS	4
5	Stem	Carbon Steel	316SS	1
6	Hex Nut	High Tensile Carbon Steel	A4	4
7	O-Ring	Nitrile	Nitrile	1
8	Hydraulic Piston	Carbon Steel	316SS	1
9	Slip Strip	PTFE	PTFE	1
10	O Ring	Nitrile	Nitrile	2
11	O Ring	Nitrile	Nitrile	1
12	Back Up Ring	PTFE	PTFE	2

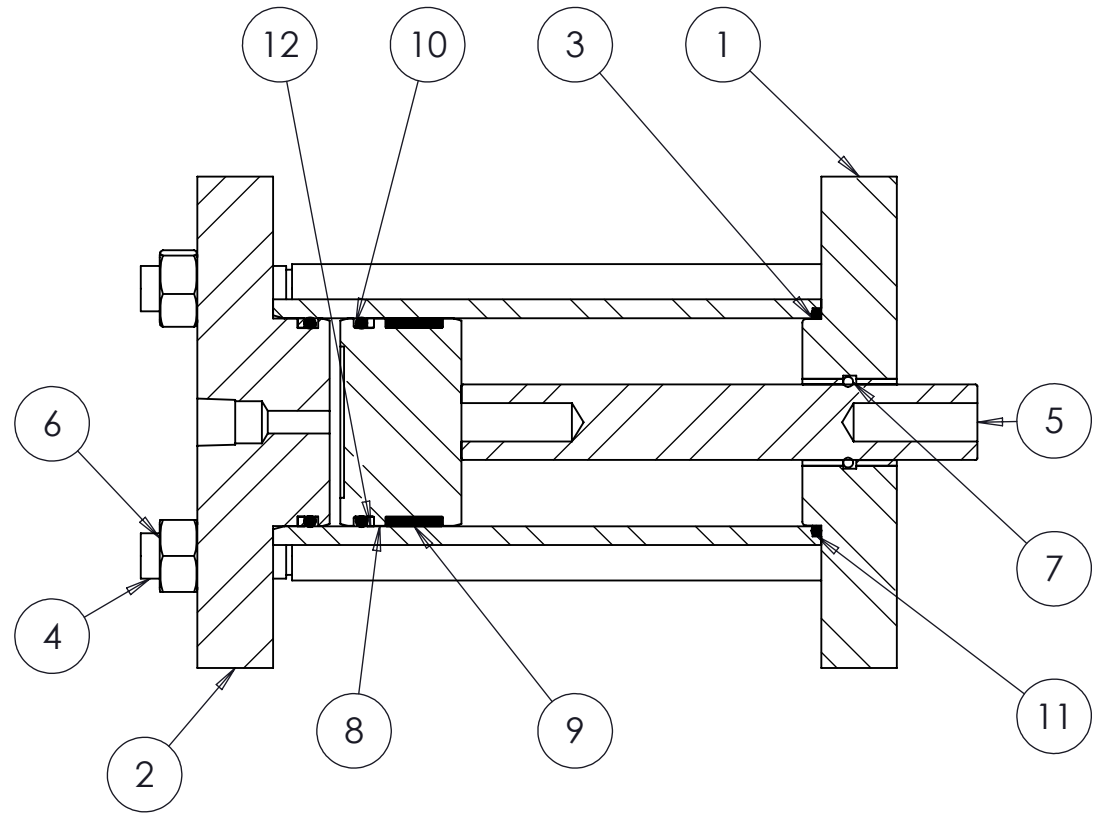

SECTION A-A  
SCALE 1 : 2

REV	DRAWN	DATE	CHK'D	ECO
	PT	14.10.14		14-2295

UNLESS OTHERWISE SPECIFIED:  
DIMENSIONS ARE IN MILLIMETERS  
SURFACE FINISH: 3.2  
TOLERANCES:  
LINEAR:  $\pm 0.25\text{mm}$   
ANGULAR:  $\pm 0.5^\circ$

TITLE:  
**Hydraulic Cylinder - Generic  
Parts - Type C Actuator**

This private & confidential drawing is the property of Camtorc Actuators, UK and cannot be copied or reproduced without the express written permission of the Company.

**Camtorc Actuators**  
United Kingdom. Tel:+44(0)870-0340002  
Website: [www.camtorc.com](http://www.camtorc.com)

DEBUR AND  
BREAK SHARP  
EDGES  
MATERIAL: Carbon Steel  
WEIGHT: 6939.74 - Excl Valve

DWG NO. **J100455**

SCALE:1:5

SHEET 1 OF 1

ACTIVE  
-  
STATUS  
R  
A4

ITEM NO.	Part Description	CS Version Material	CX Version Material	QTY
1	Spring Cylinder	Carbon Steel	316SS	1
2	Intermediate Cap	Carbon Steel	316SS	1
3	Cover Plate	Carbon Steel	316SS	1
4	Spring Piston	Carbon Steel	316SS	1
5	Stem	Carbon Steel	316SS	1
6	Spring	Spring Steel	Spring Steel	1
7	O-Ring	Nitrile	Nitrile	1
8	O-Ring	Nitrile	Nitrile	1
9	O-Ring	Nitrile	Nitrile	1
10	O-Ring	Nitrile	Nitrile	1
11	Slip Strip	PTFE	PTFE	1
12	Cap Head Screw	High Tensile Steel	A4	4
13	Hex Bolt	High Tensile Steel	A4	7
14	Hex Bolt	High Tensile Carbon Steel	A4	1
15	Dowty Washer	Carbon Steel/Nitrile	SS & Composite	2
16	Stop Rod	Carbon Steel	316SS	1

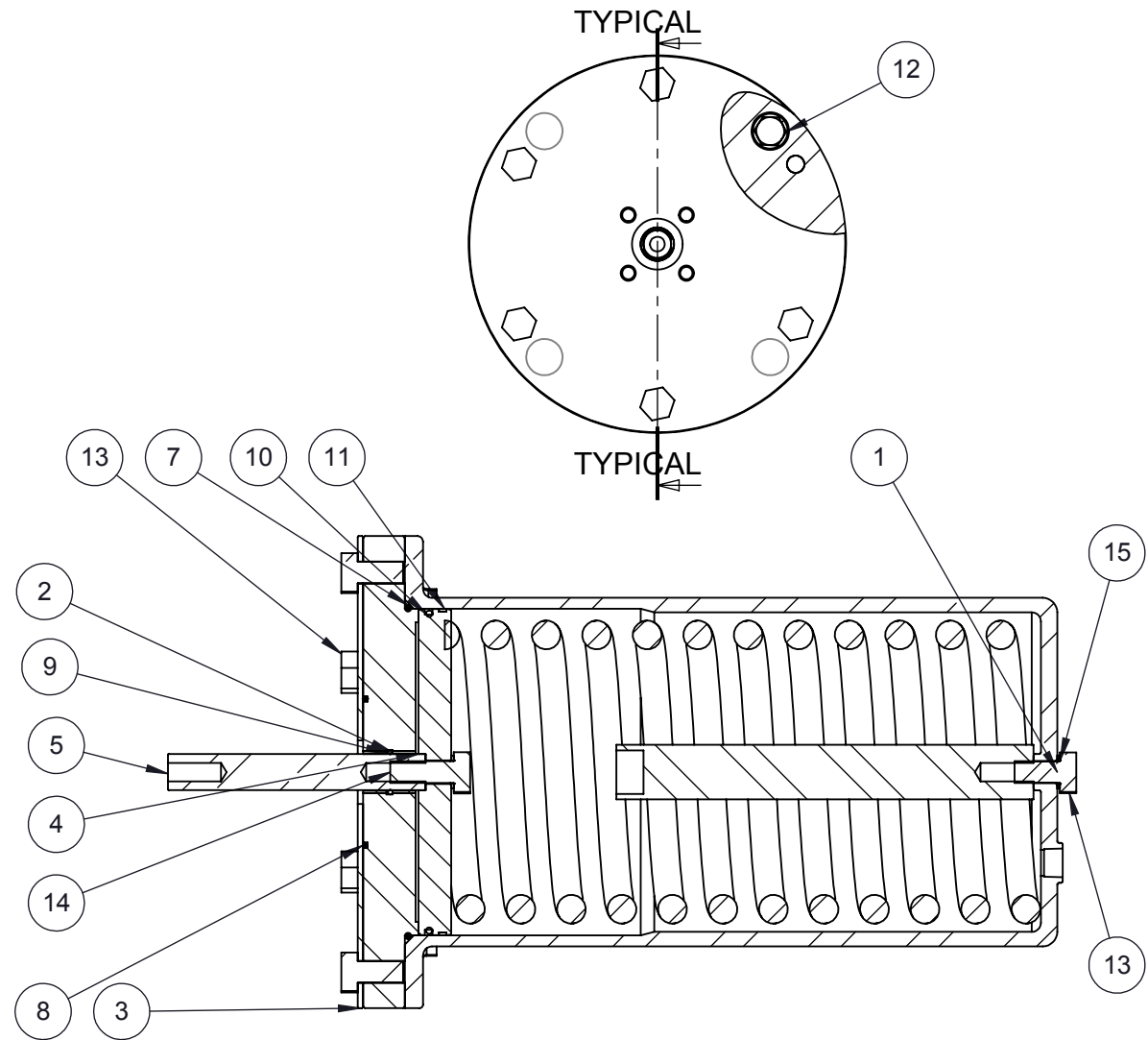

### SECTION -TYPICAL

REV	DRAWN	DATE	CHK'D	ECO
	PT	23.9.13		13-2126

UNLESS OTHERWISE SPECIFIED:  
 DIMENSIONS ARE IN MILLIMETERS  
 SURFACE FINISH: 3.2  
 TOLERANCES:  
 LINEAR:  $\pm 0.25\text{mm}$   
 ANGULAR:  $\pm 0.5^\circ$

TITLE:  
**Type C - Spring Cylinder -  
 General Assembly**

This private & confidential drawing is the property of Camtorc Actuators, UK and cannot be copied or reproduced without the express written permission of the Company.

**Camtorc Actuators**  
 United Kingdom. Tel: +44(0)870-0340002  
 Website: [www.camtorc.com](http://www.camtorc.com)

DEBUR AND  
 BREAK SHARP  
 EDGES  
 MATERIAL: Carbon Steel  
 WEIGHT: - Excl Valve

DWG NO.  
**J100454**

SCALE: 1:4

SHEET 1 OF 1

ACTIVE  
 STATUS  
 R  
 A4



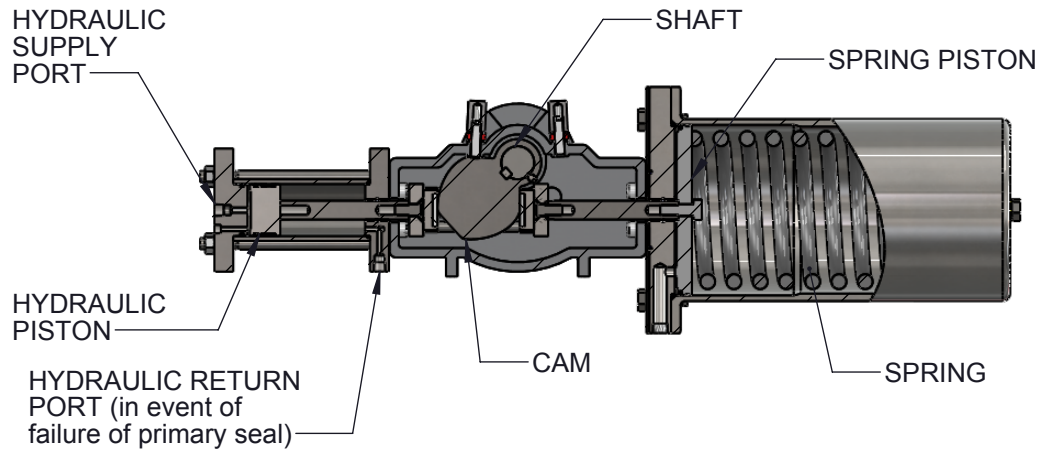

TYPE C- HYDRAULIC SPRING RETURN

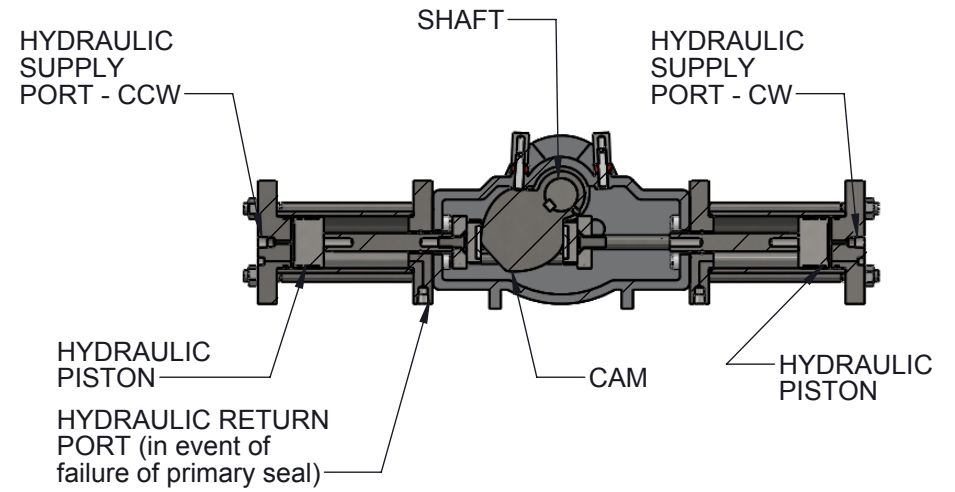

TYPE C- HYDRAULIC DOUBLE ACTING - DUAL CYLINDER

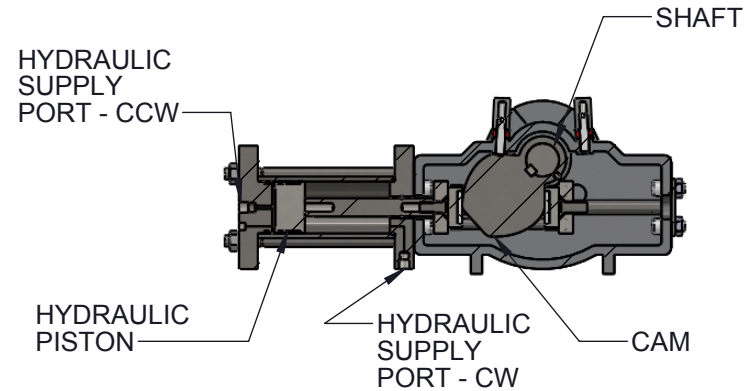

TYPE C- HYDRAULIC DOUBLE ACTING - SINGLE CYLINDER

REV	DRAWN	DATE	CHK'D	ECO
	PT	24.8.16		

UNLESS OTHERWISE SPECIFIED:  
 DIMENSIONS ARE IN MILLIMETERS  
 SURFACE FINISH: 3.2  
 TOLERANCES:  
 LINEAR: ±0.25mm  
 ANGULAR: ±0.5°

TITLE:  
**Type C - Hydraulic Actuator  
 Principle of Operation**

This private & confidential drawing is the property of Camtorc Actuators, UK and cannot be copied or reproduced without the express written permission of the Company.

**Camtorc Actuators**  
 United Kingdom. Tel:+44(0)870-0340002  
 Website: [www.camtorc.com](http://www.camtorc.com)

DEBUR AND BREAK SHARP EDGES  
 MATERIAL:  
 WEIGHT: - Excl Valve

DWG NO. **J100463**  
 SCALE:1:8  
 SHEET 1 OF 1  
 ACTIVE  
 STATUS R  
 A4

SPRING RETURN ACTUATOR - HYDRAULIC

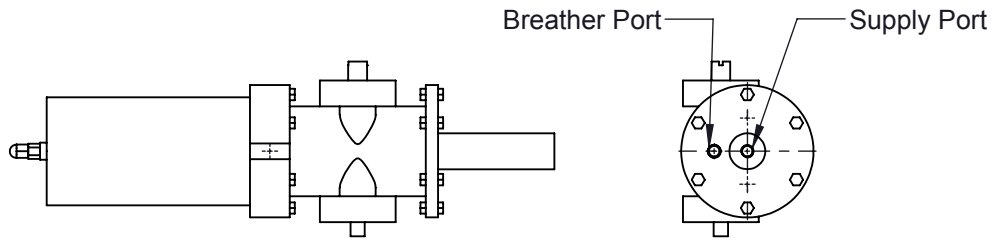

DOUBLE ACTING ACTUATOR- HYDRAULIC

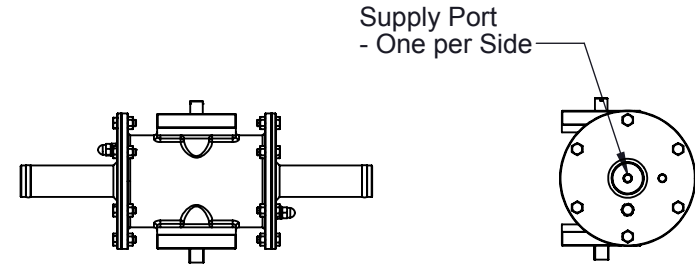

SPRING RETURN ACTUATOR - PNEUMATIC

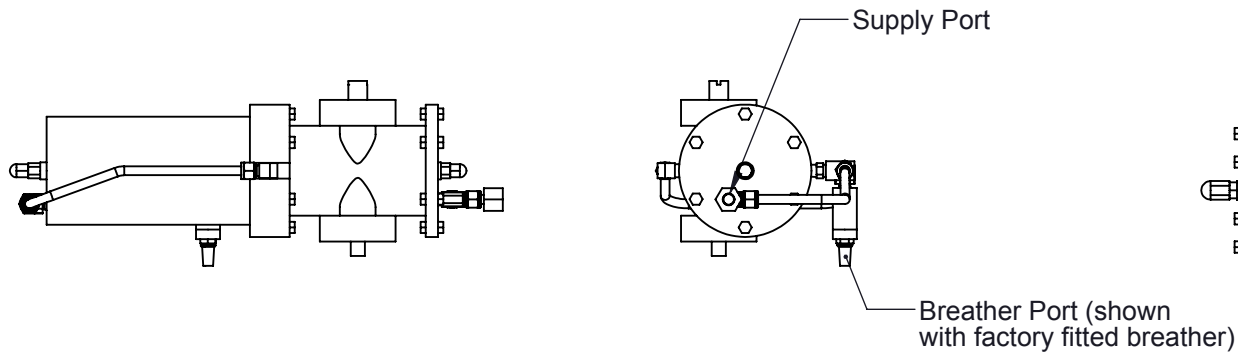

DOUBLE ACTING ACTUATOR- PNEUMATIC

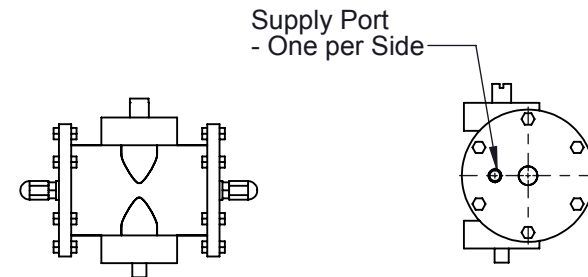

NOTE:

When Actuators are to be submersed, all ports (supply and breather) should be connected to the non-submersed area PRIOR to submersion of the Actuator. Refer to Installation, Operating and Maintenance Instruction Appendix Sheet - 'Notes on Submersible Actuators'

REV	DRAWN	DATE	CHK'D	ECO
	PT	3.9.08		08-863

UNLESS OTHERWISE SPECIFIED:  
 DIMENSIONS ARE IN MILLIMETERS  
 SURFACE FINISH: 3.2  
 TOLERANCES:  
 LINEAR: ±0.25mm  
 ANGULAR: ±0.5°

TITLE:  
**S-Type Submersible Actuator  
 - Hook Up Drawing**

This private & confidential drawing is the property of Imtex Controls Limited, Tonbridge, UK and cannot be copied or reproduced without the express written permission of the Company.

**MATIC Actuators**  
 Unit 5A, Valley Industries, Hadlow Road  
 Tonbridge, Kent, TN11 0AH, United Kingdom  
 Tel:+44(0)1732-850360 Fax:+44(0)1732-852133  
 Website: [www.matic-actuators.com](http://www.matic-actuators.com)

DEBUR AND  
 BREAK SHARP  
 EDGES  
 MATERIAL:  
 WEIGHT: - Excl Valve

DWG NO.

**J100347-SUB**

SCALE:1:8

SHEET 1 OF 1

ACTIVE

STATUS

A4